



TITLE:
**SPECIFICATION FOR STREET
LIGHTING ACCESSORIES**

Doc. No.	KP1/6C.1/13/TSP/15/002
Issue No.	2
Revision No.	3
Date of Issue	2015-10-08
Page 1 of 79	

TABLE OF CONTENTS

0.1 Circulation List

0.2 Amendment Record

FOREWORD

1. SCOPE
2. REFERENCES
3. TERMS AND DEFINITIONS
4. REQUIREMENTS
5. TESTS AND INSPECTION
6. MARKING AND PACKING
7. DOCUMENTATION

ANNEX A: *Guaranteed Technical Particulars (to be filled and signed by the Manufacturer and submitted together with relevant copies of the Manufacturer's catalogues, brochures, drawings, technical data, sales records for past five years, four customer reference letters, details of manufacturing capacity, the manufacturer's experience, copies of complete type test reports and accreditation certificate to ISO/IEC 17025 for the third party testing laboratory for tender evaluation, all in English Language)*

ANNEX B: Drawings and dimensions of columns and brackets

Issued by: Head of Section, Standards Development

Authorized by: Head of Department, Standards

Signed:

Signed:

Date: 2015-10-08

Date: 2015-10-08



TITLE:
SPECIFICATION FOR STREET LIGHTING ACCESSORIES

Doc. No.	KP1/6C.1/13/TSP/15/002
Issue No.	2
Revision No.	3
Date of Issue	2015-10-08
Page 2 of 79	

0.1 Circulation List

COPY NO.	COPY HOLDER
1	Manager, Standards
Electronic copy (pdf) on Kenya Power server (http://172.16.1.40/dms/browse.php?fFolderId=23)	

0.2 Amendment Record

Rev No.	Date (YYYY-MM-DD)	Description of Change	Prepared by (Name & Signature)	Approved by (Name & Signature)
Rev 2	2015-06-19	<ol style="list-style-type: none"> To include LED ratings for 150-169W, 170-189W, 190-209W & 210-249W Table 2 To include LED Floodlighting Luminaire rated above 250W in clause 4.3.3 	Michael Apudo	Eng. Dr. Peter Kimemia
Rev. 3	2015-10-08	<ol style="list-style-type: none"> Changed the specification code from KP1/3CB/TSP/15/002 to KP1/6C.1/13/TSP/15/002 Introduce Table 3 for LED floodlight ratings of 280W, 245W and 150W LED floodlights to replace a single rating of 400W LED. Introduced Type II and Type III of PECU. Introduced Miniature Circuit Breakers for protection of the Street Lighting Accessories 	Michael Apudo Eng. George Makowenga	Eng. Dr. Peter Kimemia 

Issued by: Head of Section, Standards Development	Authorized by: Head of Department, Standards
Signed: 	Signed: 
Date: 2015-10-08	Date: 2015-10-08



TITLE: SPECIFICATION FOR STREET LIGHTING ACCESSORIES	Doc. No.	KP1/6C.1/13/TSP/15/002
	Issue No.	2
	Revision No.	3
	Date of Issue	2015-10-08
	Page 3 of 79	

FOREWORD



This specification has been prepared by the Standards Department in collaboration with Street Lighting Section, both of The Kenya Power and Lighting Company Limited (abbreviated as KPLC), and it lays down requirements for street lighting accessories to be used in overhead street lighting. It is intended for use by KPLC in purchasing the items.

1. SCOPE

1.1. This specification is for lighting columns and brackets made from steel including lighting columns mounted on other structures, and luminaires and their accessories

1.2. This specification covers the following items:

- a) Lighting columns and brackets
 - (i) Lighting columns (8m, 10m, 12m & 15m columns)
 - (ii) Straight and curved outreach brackets
 - (iii) Straight and curved uplift outreach brackets
 - (iv) Pole & Concrete mounted outreach brackets
 - (v) Circular brackets for floodlights
- b) Luminaires (Lanterns) categories shall be as follows:-
 - (i) LED Luminaires complete with control gear;
 - (ii) LED Floodlighting Luminaires complete with control gear;
 - (iii) High Pressure Sodium (HPS) Luminaires complete with control gear
 - (iv) High Pressure Sodium Floodlight Luminaires complete with control gear (with integral ballast)
- c) High Pressure Sodium (HPS) Lamps;
- d) Photo electric cell units (PECU)
 - (i) Type I – Ordinary PECU
 - (ii) Type II - PECU complete with a Timer Switch
 - (iii) Type III – GSM enabled PECU complete with Timer Switch
- e) Streetlight Control Timers
- f) High intensity discharge ballasts for HPS luminaires
- g) Capacitors for HPS luminaires
- h) Ignitors for HPS luminaires
- i) Miniature Circuit Breakers
- j) Consumer Units
- k) Earth leakage circuit breakers
- l) Lighting contactors
- m) Clear cutouts & Isolators
- n) Fuses
- o) Cables

Issued by: Head of Section, Standards Development	Authorized by: Head of Department, Standards
Signed: 	Signed: 
Date: 2015-10-08	Date: 2015-10-08



TITLE:
SPECIFICATION FOR STREET LIGHTING ACCESSORIES

Doc. No.	KP1/6C.1/13/TSP/15/002
Issue No.	2
Revision No.	3
Date of Issue	2015-10-08
Page 4 of 79	

- p) Control pillars (Surface and pole mounted)
- q) Earth rods

1.3. The specification stipulates the minimum requirements for street lighting accessories, for use in the company and it shall be the responsibility of the supplier to ensure adequacy of the design, good engineering practice, adherence to the specification and applicable standards and regulations as well as ensuring good workmanship in the manufacture of the items for the KPLC.

1.4. The specification does not purport to include all the necessary provisions of a contract.

2. REFERENCES

The following standards contain provisions which, through reference in this text constitute provisions of this specification. Unless otherwise stated, the latest editions (including amendments) shall apply:

- ISO 9001: Quality management systems – Requirements
- ISO 1461: Hot dip galvanized coatings on fabricated iron and steel articles -- Specifications and test methods
- ISO 2409: Paints and varnishes. Cross-cut test
- IEC 62031: LED modules for general lighting (solid state lighting) -Safety specifications
- IEC 60598-2-3: Particular requirements – Luminaires for road and street lighting
- IEC 60598-2-5: Luminaires - Particular requirements — Flood lights
- IEC/PAS 62717/
PNW 34A-1445: LED modules for general lighting- Performance requirements
- IEC 60662: High Pressure Sodium Vapor Lamps specifications
- IEC 61439-3: Low-voltage switchgear and control gear assemblies
- IEC 60235: Discharge Lamps safety specifications
- IEC 60923: Ballasts for discharge lamps (excluding tubular fluorescent lamps) Performance requirements
- IEC 60926: Auxiliaries for lamps–Starting devices: General and safety requirements
- IEC 60927: Starting devices (other than glow starters) - Performance requirements

Issued by: Head of Section, Standards Development	Authorized by: Head of Department, Standards
Signed:	Signed:
Date: 2015-10-08	Date: 2015-10-08



TITLE:
SPECIFICATION FOR STREET LIGHTING ACCESSORIES

Doc. No.	KP1/6C.1/13/TSP/15/002
Issue No.	2
Revision No.	3
Date of Issue	2015-10-08
Page 5 of 79	

- IEC 61048: Capacitors for use in tubular fluorescent and other discharge lamp circuits: General and safety requirements
- IEC 61049: Capacitors for use in tubular fluorescent and other discharge lamp Circuits: Performance requirements
- IEC 60947-4-1: Low voltage switchgear and control gear—Contactors and motor Starters
- IEC 61095: Electromechanical contactors for household and similar purposes
- IEC 61439: Low Voltage switchgear and Control gear assemblies
- IEC 61008: Residual current operated circuit breaker without integral overcurrent protection for household and similar use
- IEC 61547: Equipment for general lighting purposes - EMC immunity
- IEC 62471: Photo biological safety of lamps and lamp systems
- IEC 62262: Degrees of protection provided by enclosures for electrical equipment against external mechanical impacts (IK code)
- IEC 60898-1: Electrical accessories -Circuit-breakers for overcurrent protection for household and similar installations, Part 1: Circuit-breakers for ac operation
- EN 55014-1: Electromagnetic Compatibility –Requirements for Household Appliances, Electric Tools and Similar Apparatus –Part 1: Emission
- IES LM-80-08: Method for Measuring Lumen Maintenance of LED Light sources
- IENSNA LM-58-94: Color Rendering Index and Correlated Color Temperature
- IESNA TM-16-05: IESNA technical memorandum on light emitting diode (led) sources and systems
- IESNA LM-79-08: Approved Method: Electrical & Photometric Measurement of Solid-state Lighting Products
- BS EN 40: Lighting Columns: --Part 1: Definitions and terms --Part 2: General requirements and dimensions --Part 3-1: Design and verification – Specification for characteristic loads --Part 3-2: Design and verification – Verification by testing --Part 3-3: Design and verification – Verification by calculation --Part 5: Requirements for steel lighting columns
- BS 5649: Lighting columns (All parts)

Issued by: Head of Section, Standards Development	Authorized by: Head of Department, Standards
Signed:	Signed:
Date: 2015-10-08	Date: 2015-10-08

- BS EN 1991-1-4: Actions on structure. Part 1.4 Wind Actions
- BS EN 1993-1-1: Euro code 3: Design of Steel Structures: Part 1.1: General Rules and Rules for Buildings
- BD 94/07: Design of minor structure
- PD 6547: Guidance on the use of BS EN 40-3-1 and BS EN 40-3-3
- BS 7430: Code of practice for protective earthing of electrical installations
- BS EN 1011-1 & 2: Welding. Recommendations for welding of metallic materials.—Part 1: General guidance for arc welding – Part 2: Arc welding of ferritic steels
- BS EN 288-1 & 2: Specification and approval of welding procedures for metallic materials –Part 1: Fusion welding – Part 2. Welding procedure specification for arc welding
- BS EN 287-1: Qualification test of welders —Fusion welding —Part 1: Steels
- BS 4800: Paint Colour Chart
- CIBSE: Chartered Institution of Building Services Engineers (CIBSE)
- ASTM B 117: Salt Spray (Fog) Testing
- KS 04 – 744: Specification for earth rods and their connectors. Part 1: Copper clad earth rods

3. TERMS AND DEFINITIONS

For the purpose of this specification, the definitions given in the reference standards shall apply.

4. REQUIREMENTS

4.1. Service Conditions

The street lighting accessories shall be suitable for continuous use outdoors in tropical areas of:

- (i) Altitude up-to 2200m above sea level,
- (ii) Humidity of up to 95%,
- (iii) average ambient temperature of +30°C with a minimum of -1°C and a maximum of +40°C and
- (iv) Heavy saline conditions along the coast.

Issued by: Head of Section, Standards Development	Authorized by: Head of Department, Standards
Signed: 	Signed: 
Date: 2015-10-08	Date: 2015-10-08



TITLE: SPECIFICATION FOR STREET LIGHTING ACCESSORIES	Doc. No.	KP1/6C.1/13/TSP/15/002
	Issue No.	2
	Revision No.	3
	Date of Issue	2015-10-08
	Page 7 of 79	

- (v) Pollution: Design pollution level to be taken as "Heavy" (Pollution level III) for inland and "Very Heavy" (Pollution level IV) for coastal applications in accordance with IEC 60815.
- (vi) Isokeraunic level: 180 thunderstorm days per year

4.2. LIGHTING COLUMNS AND BRACKETS

4.2.1. Design and construction

- 4.2.1.1. The design, manufacture and installation of lighting columns and brackets shall comply with BS EN 40-1 & 2; BS EN 40-3-1 and BS EN 40-3-3 (BS 5649 – relevant parts) for the design; BS EN 1991-1-4 for wind actions; BS EN 1993-1-1 for structural strength as per Table 1.
- 4.2.1.2. The design life shall not be less than 25 years, unless otherwise required by the Technical Approval Authority in accordance with BD 94/07.
- 4.2.1.3. Columns and brackets shall be designed to satisfy the relevant ultimate limit states and the serviceability limit state, including, for steel structures, meeting fatigue criteria in accordance with EN 1993-1-1 especially for:
 - (i) The flanges – at the weld throat between the column and flange; in the parent metal adjacent to the weld; any stiffening between the column and the flange
 - (ii) Door openings - at welded attachments and at poorly finished cut edges;
 - (iii) Shoulder joints - at the weld throat and in the parent metal adjacent to the weld.
- 4.2.1.4. The dimensional requirements for lighting columns shall be in accordance with EN 40-2 and Annex B. The overall dimensional limitations for the lighting brackets and columns covered by this specification shall be:
 - (i) Post top columns (for floodlights) – 12m & 15m nominal height
 - (ii) Columns with brackets (for HPS and LED luminaire) 8m, 10m, 12m & 15m nominal height
 - (iii) Bracket projections - not exceeding the lesser of 0.25 x nominal height or 3m
- 4.2.1.5. The minimum thickness of structural steel sections used in column and bracket design shall be as follows:
 - (i) Plates and sections other than hollow sections shall be at least 6 mm
 - (ii) Hollow sections effectively sealed by welding, other than a small drain hole with a diameter of between 10mm and 15mm shall be at least 5 mm for columns and at least 4 mm for brackets.
- 4.2.1.6. The end plates measuring 375 x 375mm shall be joined by continuous structural quality welding to BS EN 1011: Parts 1 and 2. Should there be a possibility of

Issued by: Head of Section, Standards Development	Authorized by: Head of Department, Standards
Signed:	Signed:
Date: 2015-10-08	Date: 2015-10-08



TITLE: SPECIFICATION FOR STREET LIGHTING ACCESSORIES	Doc. No.	KP1/6C.1/13/TSP/15/002
	Issue No.	2
	Revision No.	3
	Date of Issue	2015-10-08
	Page 8 of 79	

water entering and subsequently freezing, then drain holes shall be provided. The size of the hole shall be appropriate to the void being drained, but shall not be less than 10 mm or greater than 15 mm diameter. Hollow sections in non-corrosive or galvanized steel shall be provided with such drain holes at all low points.

- 4.2.1.7. The method of joining the base section and the shaft shall be by a swage joint with an internal centralizing washer. All welding procedures shall be in accordance with the requirements of BS EN 288 and all welders approved to the requirements of BS EN 287 with welding carried out in accordance with BS EN 1011: Parts 1 and 2.
- 4.2.1.8. Where a separate bracket is fixed to a column, the assembly of the column shaft and bracket shall incorporate a mechanical locking system using stainless steel bolts, in addition to high tensile socket headed securing screws and it shall be possible to fix the bracket in any of 4 x 90° positions relative to the door opening.
- 4.2.1.9. When correctly fixed, the design of the bracket shall not allow any movement of the bracket either vertically or horizontally with respect to the column. At the point of interconnection, the cross-section of the bracket shall, preferably, equal that of the column shaft. Brackets shall blend with their columns, in material, finish and colour and shall be as short as practicable.
- 4.2.1.10. Base compartments shall afford easy access to cable terminations and wiring. All electrical equipment mounted in the base compartment shall be securely fixed to a 15mm minimum thickness backboard which shall be of a non-hygroscopic material of sufficient size to accommodate any control gear and cable termination units.
- 4.2.1.11. Doors, shall be sealed to minimum IP33, shall be provided with a substantial and positive, triangular-headed, tamper proof lock. The locking mechanism shall be lubricated with grease immediately following installation and if necessary prior to adoption. Two keys per 10 columns, with a minimum requirement of two keys shall be provided to the Street Lighting Engineer at time of delivery to KPLC stores.
- 4.2.1.12. The earthing terminal shall be provided for steel columns and their doors shall comprise a brass or stainless steel bolt, size M8, complete with nuts and washers. The column shall have a cable entry slot 75mm in width.

Issued by: Head of Section, Standards Development	Authorized by: Head of Department, Standards
Signed:	Signed:
Date: 2015-10-08	Date: 2015-10-08



TITLE:
SPECIFICATION FOR STREET LIGHTING ACCESSORIES

Doc. No.	KP1/6C.1/13/TSP/15/002
Issue No.	2
Revision No.	3
Date of Issue	2015-10-08
Page 9 of 79	

4.2.2. Materials of manufacture



Columns and brackets shall be manufactured from welded carbon steel tube to BS EN 10210, steel grade S355J2, with minimum tensile strength of 470-630 MPa, minimum yield strength of 355 MPa and minimum percentage elongation of 22% or equivalent as detailed below and as stated in Annex B:

- (i) Circular tubular steel manufactured from cold-formed hollow sections without heat treatment with constant shaft diameter above the base compartment
- (ii) Continuously tapered steel with either circular or polygonal cross-section

4.2.3. Protection against corrosion

4.2.3.1. Steel columns and brackets shall be protected against corrosion at the fabricator's works by the following system:

- a) Surface preparation: the complete column and/or bracket shall be hot-dip galvanized to comply with the requirements of ISO 1461. The average coating mass shall not be less than 610 g/m², (equivalent to a nominal coating thickness of 85 microns) for flat articles (tubes included) and not be less than 390 g/m², (equivalent to a nominal coating thickness of 55 microns) for centrifuged articles.
- b) When specified on the tender, further treatment of the galvanized surface shall then be degreased and left with a smooth finish to prepare for painting. The paint system shall comprise:
 - (i) 1st Coat - On the internal root section, to 250mm above ground level and on the overall external surfaces, one coat of Mordant Solution, T wash.
 - (ii) 2nd Coat - On the internal root section, to 250mm above ground level, one coat of modified vinyl micaceous iron oxide with high solids to give a high build coating colour grey to provide a minimum dry film thickness of 60 microns.
 - (iii) 3rd Coat - On the external surface overall, one coat of two pack high build epoxy zinc phosphate primer, light grey to provide a minimum dry film thickness of 75 microns.
 - (iv) 4th Coat - On the external root section to 250mm above ground level, one coat of modified vinyl micaceous iron oxide with high solids to give a high build coating, coloured grey to provide a minimum dry film thickness of 75 microns.
 - (v) 5th Coat - On the external surface overall, one coat of modified vinyl with high solids to give a sheen finish to the dried film colour grey from BS 4800 shade 18B25 to provide a minimum dry film thickness of 60 microns. A line on the circumference of the base section shall denote ground level. The minimum dry film thickness shall be:

Issued by: Head of Section, Standards Development	Authorized by: Head of Department, Standards
Signed: 	Signed: 
Date: 2015-10-08	Date: 2015-10-08

- Root - 60µm (internal) 210µm (external to 250mm)
- External - 135µm (from 250mm)

4.2.3.2. In general, galvanized steel columns shall be left unpainted; however, where columns require painting the developer shall submit details of the proposed paint system to be used to the Chief Engineer, Street Lighting for approval before undertaking any work.

Table 1: Technical particulars of the columns and brackets as per EN 40 (relevant parts)

Particulars		Requirements
Performance under vehicle impact (Impact tested at km/h)	Untested	Class 0
	Tested	100:NE:3
Partial load factor class		B
Deflection class		3
Maximum wind velocity withstand, m/s		26
Maximum luminaire weight , Kg.	>10m	20
	<10m	10
Maximum luminaire windage, m ²		0.25
Minimum terrain category		II

4.2.4. Marking and labeling of columns and brackets

4.2.4.1. All columns and brackets shall carry a unique identification mark which indicates:

- The name or symbol of the manufacturer,
- Year of production and manufacturer's batch number.
- Standard of manufacture
- The identification mark shall be permanent, legible and clearly visible and shall be located within the base compartment of the column.

4.2.4.2. There shall be a CE marking with the following mandatory requirements

- Resistance to horizontal loads (type of verification i.e. testing (T) – EN 40-3-2 or calculation (C)- EN 40-3-3;
- Reference wind velocity;
- Windage area;
- Weight at top
- Deflection class
- Terrain category if different to II.

Issued by: Head of Section, Standards Development

Authorized by: Head of Department, Standards

Signed:



Signed:



Date: 2015-10-08

Date: 2015-10-08



TITLE:
SPECIFICATION FOR STREET LIGHTING ACCESSORIES

Doc. No.	KP1/6C.1/13/TSP/15/002
Issue No.	2
Revision No.	3
Date of Issue	2015-10-08
Page 11 of 79	

4.2.5. Sizes

4.2.5.1. Street lighting columns complete with bracket

- 4.2.5.1.1. The columns shall be of two types namely Tubular Column Rooted and Flange Plated complete with various bracket arrangements
- 4.2.5.1.2. The sizes shall be 8m, 10m, 12m and 15m with their brackets having projection lengths of 1.5m, 2.0m, 2.5m and 3.0m in accordance with the drawings and dimensions in Annex B and shall be specified in the tender.
- 4.2.5.1.3. Columns complete with brackets shall be supplied together already fixed at the time of delivery.
- 4.2.5.1.4. All tubular rooted columns shall have a root for planting to a depth shown by the middle range as stated in Clause 5 of Part 2 of BS 5649 and Annex B as follows:
 - a) The columns shall have a root for planting to a depth 1200mm, 1500mm, 1700mm and 2,000mm for 8m, 10m, 12m and 15m columns respectively.
 - b) The columns shall have a cable entry slot of 65mm x 150mm with the top of the slot 500mm below ground level.
- 4.2.5.1.5. Flange Plated columns shall have a flange plate as per the drawings in Annex B.

4.2.5.2. Street lighting bracket without columns

- 4.2.5.2.1. The brackets (lighting heads) without columns shall be classified in the following categories and the KPLC requirement shall be specified in the tender:
 - (i) Outreach brackets for lighting columns for mounting on columns.
 - Single straight or curved brackets
 - Double straight or curved brackets
 - (ii) Curved outreach brackets for wood and/or concrete mountings.
 - (iii) Circular floodlight brackets for mounting on columns and masts.
 - 4-way circular brackets
 - 6-way circular brackets
- 4.2.5.2.2. The outreach brackets shall be designed; manufactured and tested in accordance with clauses 4.2.1, 4.2.2, 4.2.3 and 4.2.4 of this specification and shall have the following projection lengths: 1.0m, 1.5m, 2.0m, 2.5m, 3.0m as per the drawings in Annex B – for straight and curved brackets

Issued by: Head of Section, Standards Development

Authorized by: Head of Department, Standards

Signed:

Signed:

Date: 2015-10-08

Date: 2015-10-08



TITLE: SPECIFICATION FOR STREET LIGHTING ACCESSORIES	Doc. No.	KP1/6C.1/13/TSP/15/002
	Issue No.	2
	Revision No.	3
	Date of Issue	2015-10-08
	Page 12 of 79	



4.2.5.2.3. The circular floodlight brackets shall be suitable for top post mounting on the 12m steel columns and shall have dimensions matching with the columns. The spigot lengths shall be as per Table 3 of Annex B, with the fixing diameters matching with that of the 12m columns. The spigot shall be fixed using four (4) stainless steel bolts properly spaced for stability after fixing. The diameters of circular floodlight brackets shall not be fixed but vary from 0.9-1.15m for 4-way and 1.15-2.0m for 6-way brackets.

NOTE: *The drawings in Annex B are only for illustrative purposes and not restrictive to the design. Bidders shall be required to submit design drawings for columns and brackets with full matching dimensions that conform to the requirements of this specification during tender to KPLC for purposes of tender evaluation.*

4.3. LUMINAIRES (LANTERNS)

4.3.1. General design and construction.

- 4.3.1.1. Luminaires (lanterns) in this specification shall include High Pressure Sodium (HPS), Light Emitting Diode (LED) and Floodlight lanterns (LED & HPS) complete with their control gear. The luminaire shall include the reflector, the refractor, and the housing.
- 4.3.1.2. The luminaires shall be manufactured to IEC 60598-1 and IEC 60598-2-3 standards and shall incorporate an efficient optical system to direct the light onto the highway to ensure minimum environmental pollution of the night sky of the upward light emitted. Luminaires will be specified with due consideration of the Institution of Lighting Professionals Guidance Notes for the Reduction of Obtrusive Light and shall be of the side entry type.
- 4.3.1.3. All luminaires shall be constructed from LM5 marine grade aluminium or equivalent with a polyester powder coating, grey, silver or black, over a ROHS compliant chrome passivation substrate; the polyester powder coat finish that shall withstand the standard cut tests as defined in ISO 2409.
- 4.3.1.4. Luminaires shall have an integral flexible mounting system and be capable of being mounted 42mm to 60mm diameter side entry and 60mm to 76mm post top mounted without the need for separate spigot adaptors.
- 4.3.1.5. Luminaires shall be environmentally friendly and all component parts shall be 98% recyclable at the end of life.



Issued by: Head of Section, Standards Development	Authorized by: Head of Department, Standards
Signed: 	Signed: 
Date: 2015-10-08	Date: 2015-10-08



TITLE:
SPECIFICATION FOR STREET LIGHTING ACCESSORIES

Doc. No.	KP1/6C.1/13/TSP/15/002
Issue No.	2
Revision No.	3
Date of Issue	2015-10-08
Page 13 of 79	

- 4.3.1.6. Bowls/protectors shall be vandal resistant and stabilized to minimize loss of transparency due to weathering and exposure to ultra violet light.
- 4.3.1.7. Fully assembled luminaires shall weigh 14kg maximum, with a maximum windage of 0.15m² and impact rating shall be IK08 minimum in accordance with IEC 62262.
- 4.3.1.8. The luminaires shall have double insulation with a protection class of at least class II in accordance with IEC 60598-1 and the luminaire optical system and the control gear compartment shall have a minimum protection rating of IP66 in accordance with IEC 60529.
- 4.3.1.9. Luminaires shall be reasonably weather and dust-proof and shall be fitted with a suitable gasket between the body of the lantern and the bowl. The IP Rating of the lantern shall not be less than IP 65 in accordance with IEC 60529.
- 4.3.1.10. Luminaires shall be self-clean and be designed to prevent jamming injuries during installation and be free of sharp edges. Luminaires shall be designed to prevent the supply cable being damaged during installation.
- 4.3.1.11. Luminaires shall have integral control gear and an option to retrofit proprietary front and/or rear shields, which shall reduce unwanted spill. The colour of the shields shall match the luminaire.
- 4.3.1.12. Photometric data shall be based on test results from a verified laboratory using absolute photometry in accordance with methods and conditions detailed in LM-79-08 or equivalent.
- 4.3.1.13. The bowl or other component giving access to the interior of the lantern shall, when in a closed position, be firmly attached to the body of the lantern; in the open position it shall be attached in such a way that there is no likelihood of it becoming accidentally detached.
- 4.3.1.14. All hinges, toggle catches, captive screws and nuts shall be made of non-corrosive material. A proof of the same shall be submitted for purposes of tender evaluation.
- 4.3.1.15. The optical equipment controlling distribution shall include high purity aluminium reflectors and/or prismatic refractors and these shall have a smooth exterior surface or be protected by hermetically sealed cover plates to prevent an accumulation of dirt and to facilitate cleaning. Refractors wholly within a totally enclosed lantern need not be sealed.

Issued by: Head of Section, Standards Development	Authorized by: Head of Department, Standards
Signed: 	Signed: 
Date: 2015-10-08	Date: 2015-10-08



TITLE: SPECIFICATION FOR STREET LIGHTING ACCESSORIES	Doc. No.	KP1/6C.1/13/TSP/15/002
	Issue No.	2
	Revision No.	3
	Date of Issue	2015-10-08
	Page 14 of 79	

- 4.3.1.16. All luminaires shall be fitted with integral control gear and have a heat barrier between the lamp enclosure and gear compartment. The control gear shall be fitted to a tool-less, quick release gear tray, equipped with a plug and socket connector for ease of maintenance or replacement purposes.
- 4.3.1.17. Electrical equipment shall be installed so that levels of radio interference given in IEC 55014-1 are not exceeded.
- 4.3.1.18. Luminaires shall be of full cut-off type and shall provide a light output ratio of 90% with and upward lighting output ratio of no more that 0.5% and IESNA Type 2 or 3 distributions.
- 4.3.1.19. Luminaires shall be securely fitted to bracket arms or columns and the lamp and all parts affecting the photometric performance shall be in a clean condition and correctly orientated.

4.3.2. LED Luminaires complete with Control Gear



- 4.3.2.1. The LEDs luminaires shall fully comply with the provisions of clause 4.3.1 and it shall be designed, manufactured and tested in accordance with IEC 60598-2-3, LED safety shall conform to IEC 62031 and IEC 62035 with performance requirements complying fully with provisions of IEC/PAS 62717 and PNW 34A-1445.
- 4.3.2.2. The LEDs & LED Modules-Drivers shall comply with IEC 61000-3-2, IEC 61347-2-13, IEC 61000-3-3, IEC 61347-1, IEC 61347-2-1, IEC 61347-2-8, IEC 61347-2-9, IEC 60921 and IEC 60923 and subsequent amendments as appropriate and be tap selected to specified operating voltage.
- 4.3.2.3. All LED drivers shall be contained within the lanterns housing and shall have a voltage range of 220-250V, 50Hz with other ratings as per Table 2.
- 4.3.2.4. The LED driver, operating at constant current, shall be housed in a separate gear compartment to LED modules. The driver shall have a minimum operating efficiency of 90%.
- 4.3.2.5. The driver shall be independently tested and EN-EC certified in accordance with IEC 60598-1 and IEC 60598-2-3 by an independent approval body recognized by the International Community; current validation certification must be provided during tender.

Issued by: Head of Section, Standards Development	Authorized by: Head of Department, Standards
Signed: 	Signed: 
Date: 2015-10-08	Date: 2015-10-08



TITLE: SPECIFICATION FOR STREET LIGHTING ACCESSORIES	Doc. No.	KP1/6C.1/13/TSP/15/002
	Issue No.	2
	Revision No.	3
	Date of Issue	2015-10-08
	Page 15 of 79	

- 4.3.2.6. LED luminaires shall have a facility to fit additional LED's or modify existing fittings to provide surround light to properties to extend the field of luminance and when post top mounted must be capable of being set at adjustable inclinations.
- 4.3.2.7. Luminaires for use with LED's shall be suitable for the operation of both the standard and higher lumen output arrays.
- 4.3.2.8. The LED luminaire shall include surge protection by means of a transient voltage suppression chip or equivalent, designed to provide uniformity of lighting output in the event of individual LED failures and effectively control thermal management suitable for the use at an ambient temperature of 15° C.
- 4.3.2.9. The LED system surge protection shall survive 250 repetitive strikes of "C Low" (C Low: 6kV/1.2 x 50 μs, 10kA/8 x 20 μs) waveforms at 1-minute intervals with less than 10% degradation in clamping voltage. "C Low" waveforms are as defined in IEEE/ASNI C62.41.2-2002, Scenario 1 Location Category C.
- 4.3.2.10. The driver shall be tested in accordance with NEN-EN-IEC62471 (2006-07) for Photo-Biological Safety and shall comply with Group 1 classification; current validation must be provided.
- 4.3.2.11. All terminals shall be shrouded to IP2X so that live parts cannot be accidentally touched. They shall be fitted with group 1 classification, current valid certification must be provided.
- 4.3.2.12. Drivers shall be compatible with all other components including LED and Photo-Electric Control Units (PECU) with a stable power consumption over full operating voltage range.
- 4.3.2.13. Drivers shall indicate all wiring connections and operating voltages via indelible markings in accordance with IEC/PAS 62717 and PNW 34A-1445. This shall be confirmed at the time of acceptance.
- 4.3.2.14. The LED driver shall be protected against overheating by an over-temperature sensing system and with a Total Harmonic Distortion (THD): ≤ 20% and shall comply with FCC Title 47 CFR Part 18 Non-consumer RFI/EMI Standards. The drivers shall have a reduction of hazardous substances (ROHS)-compliance marking.
- 4.3.2.15. Lumen maintenance life time testing shall be in accordance with LM80 or equivalent and extrapolated methodologies as per TM-21; current validation must be provided. The measured lumen maintenance shall correspond with the "lumen maintenance code 8" or greater.

Issued by: Head of Section, Standards Development	Authorized by: Head of Department, Standards
Signed: 	Signed: 
Date: 2015-10-08	Date: 2015-10-08



TITLE:
SPECIFICATION FOR STREET LIGHTING ACCESSORIES

Doc. No.	KP1/6C.1/13/TSP/15/002
Issue No.	2
Revision No.	3
Date of Issue	2015-10-08
Page 16 of 79	

- 4.3.2.16. LED flux and luminaire data shall be presented for an ambient temperature of 15^o Celsius and the light source data shall be measured at a junction temperature of 25^oCelsius. This shall be submitted for purposes of tender evaluation.
- 4.3.2.17. The LED module efficacy shall not be less than 90% of the rated LED module efficacy as declared by the manufacturer in accordance with clause 8.3 of IEC/PAS 62717.
- 4.3.2.18. Colour correlated temperature (CCT) of the LED's shall be equal to or greater than 4000K (Kelvin) and tolerances beyond a 5 step Macadam ellipse shall not be acceptable as per Table 5 of IEC/PAS 62717 Part PNW 34A-1445.
- 4.3.2.19. Rated Colour Rendering Index shall be code 7 (CRI) range 67-76) or greater and shall be measured in accordance with CIE 13.3 and CIE 177.
- 4.3.2.20. Each LED shall be mounted beneath an individual lens providing photometric footprint base on an overlay methodology and mounted within a self-contained module (LED module) that can be removed, replaced using simple tools and lenses and manufactured from optical grade polycarbonate or PMMA acrylic thermoplastic.
- 4.3.2.21. In order to maximize opportunities for KPLC to benefit from advances in LED technology and product developments, the proposed equipment shall be flexible and allow for easy installation of upgrades and replacements.
- 4.3.2.22. The system power factor shall be greater than 0.95 at full power.
- 4.3.2.23. All LED luminaires shall be supplied fully assembled in all respects with LED and photo electric control unit at 70/35 lux.
- 4.3.2.24. The LEDs shall be of Hi-flux/Hi-power white LEDs producing a minimum of 90% of initial intensity at 50,000 hours of life / 10year minimum.
- 4.3.2.25. The LEDs shall be 100% mercury and lead free.
- 4.3.2.26. The LEDs micro-lens systems shall be of full cut-off type, producing IESNA Type 2 or Type 3 light distributions. The Luminaire shall produces 0% total lumens above 90^o (BUG Rating, U=0). The BUG rating shall be B2 U0 G2.

Issued by: Head of Section, Standards Development

Authorized by: Head of Department, Standards

Signed:

Signed:

Date: 2015-10-08

Date: 2015-10-08

- 4.3.2.27. The LED luminaires with LED arrays shall have a 5 year limited warranty covering the LED arrays and LED drivers. Emergency components and batteries shall have a 1 year warranty.
- 4.3.2.28. The LED & LED Modules-Drivers shall comply with the following minimum system performance criteria and a proof of the same shall be submitted together with the tender for evaluation:
- The T_c life shall be + 65°C,
 - The LEDs shall have a system lifetime @ T_c life (min 90%) of at least 50,000 hrs
 - The T_c min shall be at least - 20 °C (start up at - 40°C)
 - The T_c max shall be + 75 °C
 - The T_c thermal cutoff module shall be + 75°C (starts dimming)
 - The T_c thermal cutoff driver shall be + 85°C (maximum dimming)
 - The input voltage shall be 220-250V
 - Shall be suitable for at least insulation protection class I.



Table 2: LED performance ratings in accordance with IESNA TM-16-05

Ratings			
Input Power (W)	Minimum luminous efficacy Lm/W	Input Current (mA)	Lumens (Lm), min
150 - 169	100	350 - 1050	15,000
170 - 189			17,000
190 - 209			19,000
210 - 249			21,000

4.3.3. LED Floodlighting Luminaires

4.3.3.1. General

- 4.3.3.1.1. The LEDs luminaires shall fully comply with the provisions of clause 4.3.1 and 4.3.2.1-4. The luminaire shall be designed for aggressive ambient conditions including salt mist and high humid environments. The manufacturer shall have test records showing the successful completion of a 2500 hour salt spray test of the luminaire.
- 4.3.3.1.2. All external screws, bolts, washers etc. shall be of V4A (1.4401) or equivalent stainless-steel. The bracket shall enable a stepless tilting of the floodlight.

Issued by: Head of Section, Standards Development	Authorized by: Head of Department, Standards
Signed: 	Signed: 
Date: 2015-10-08	Date: 2015-10-08



TITLE: SPECIFICATION FOR STREET LIGHTING ACCESSORIES	Doc. No.	KP1/6C.1/13/TSP/15/002
	Issue No.	2
	Revision No.	3
	Date of Issue	2015-10-08
	Page 18 of 79	

4.3.3.1.3. The floodlight luminaire shall have a low profile to minimize the structural load. The luminaire shall have a wind load lower than 0.1 m² at 0° tilting angle.

4.3.3.1.4. Optional powder coating of aluminium shall be available for extreme conditions, with 500 hour salt spray test as defined in ASTM Standard B 117

4.3.3.2. Tilt Angle

4.3.3.2.1. The tilt angle of the luminaire in normal operation shall not exceed 15° to avoid light pollution and glare towards the road users as per IESNA LM-79-08 standards.

4.3.3.2.2. The ULR (Upward Light Ratio) value shall be 0.0% eliminating light pollution and wasted energy costs.

4.3.3.3. Protection

4.3.3.3.1. The floodlight shall have a minimum ingress protection rate of IP65 in accordance with IEC 60529. The luminaire shall not require cooling fins (finned heat sinks) to avoid dirt collection resulting in a reduction of the cooling capacity and reduced life of the LEDs.

4.3.3.3.2. All optical and electronic components shall be protected by a single layer hardened glass cover with a minimum transmission factor of 95%. The glass cover should be able to be opened without any tools.

4.3.3.3.3. All cables inside the floodlight shall have two (2) protective layers (double-isolated).

4.3.3.4. LED Lighting Units

4.3.3.4.1. The floodlight shall be composed of individual replaceable LED lighting units. The optical part shall be made of high-transparent, non-yellowing PMMA.

4.3.3.4.2. In case of partial default the system can be replaced in parts. The replacement of an LED lighting unit shall be via a plug connection requiring no special tools or on-site wiring.

4.3.3.4.3. To enable efficient spare parts management, the LED lighting units shall be interchangeable with the manufacturer's other LED lighting products for applications including service roads, parking areas etc.

Issued by: Head of Section, Standards Development	Authorized by: Head of Department, Standards
Signed: 	Signed: 
Date: 2015-10-08	Date: 2015-10-08

4.3.3.5. Built in Redundancy

4.3.3.5.1. The floodlight shall be equipped with a multi-layer optical system that ensures equal uniformity at the reference surface in the event of partial failure of the lighting system. A single LED lighting unit failure shall never result in a decrease below the uniformity value of 4:1 ratio required by CIBSE standards.

4.3.3.5.2. The manufacturer shall be able to demonstrate via lighting calculations and false colour rendering drawings that even by turning OFF 50% of the floodlight luminaires, the lighting system still meets the 4:1 uniformity ratio required by CIBSE standards.

4.3.3.6. Hot Restrike (Instant On)

In the event of power failure, each floodlight shall be at full light output when the power returns. Full light output power must be reached within one (1) second. No additional equipment shall be required to be installed such as hot restrike equipment.

4.3.3.7. Control

The floodlight shall include an LED driver capable of controlling the luminaire via either an industry standard DALI (Digital Addressable Lighting Interface) or a 1-10V control interface.

4.3.3.8. Surge Protection



The floodlight shall include an integrated two (2) stage surge protection system to protect the electronic driver (1st stage) with a minimum surge protection rating of 10KV and the LED lighting units (2nd stage) with a test class II surge protection in accordance with IEEE/ANSI C62.41.2.

4.3.3.9. Colour Rendering Index

The floodlight shall have a minimum colour rendering index (Ra) of 80 and a colour temperature minimum of 4,000 K for maximum efficiency in accordance with INSNA LM-58-94.

4.3.3.10. Operational Life Expectancy

The floodlight shall have a lifetime (MTBF - Mean Time Between Failures) of 50,000 hours (L70). The lumen output shall not drop below 70% of the initial output during this period.

Issued by: Head of Section, Standards Development	Authorized by: Head of Department, Standards
Signed: 	Signed: 
Date: 2015-10-08	Date: 2015-10-08

4.3.3.11. Compliance and rating

4.3.3.11.1. The floodlight shall enable for CIBSE compliant illuminations. The manufacturer shall be ISO 9001 and ISO 14001 certified.

4.3.3.11.2. The luminaire shall allow an optimal maintenance with reduced recycling and related costs. The floodlight shall have the performance ratings operating at 700mA as per Table 3

Table 3: LED floodlight performance ratings in accordance with IESNA TM-16-05

LED floodlight Input Power	Input Current (mA)	Minimum Lumen Efficacy, Lm/W	Lumen Output Lm
≥400W	350 - 1050	100	40,000
350-399W			35,000
300-349W			30,000
250-299W			25,000

4.3.3.12. Certifications

4.3.3.12.1. The floodlight shall be CE certified and all components shall be ENEC and UL certified. The floodlight shall allow the roadways to reduce energy consumption and CO₂-emission significantly.

4.3.3.12.2. The floodlight shall have a photobiological certificate in compliance with IEC 62471 validating the safety of the LEDs and shall not be classified higher than "Exempt Risks".

4.3.3.12.3. The floodlight shall be RoHS compliant.

4.3.4. High Pressure Sodium Luminaires complete with Control Gear

4.3.4.1. General requirements

4.3.4.1.1. High Pressure Sodium (HPS) luminaires shall comply with IEC 60598-2-3, IEC 60235 and IEC 60662 for the lamps with all the luminaire qualities described in clause 4.3.1.

4.3.4.1.2. It shall have EC Declaration mark to ascertain conformity and a certificate shall be provided by the bidder during tender for confirmation.

Issued by: Head of Section, Standards Development

Authorized by: Head of Department, Standards

Signed:



Signed:



Date: 2015-10-08

Date: 2015-10-08

4.3.4.2. Specific requirements

- 4.3.4.2.1. High pressure sodium (HPS) luminaires shall be of the "Plus" type with higher xenon pressure for increased lm/W.
- 4.3.4.2.2. The HPS luminaire shall have a means of supporting the lamp so designed that the position of the lamp in the lantern relative to any optical equipment remains substantially the same under all conditions of service and throughout the life of the lantern.
- 4.3.4.2.3. HPS luminaires shall be fitted with a porcelain terminal block, earth terminal, cable clamp and lamp holder ready wired to connector block with heat resisting type cable.
- 4.3.4.2.4. The construction shall be sturdy and robust with as few welds as possible in order to reduce the risk of early failures due to external shock and vibration during transportation and installation.
- 4.3.4.2.5. The ballasts specification shall be as per clause 4.7 and shall be approved for use under the Balancing and Settlement Code (BSC) Unmetered Supplies Arrangements and shall have all necessary UMSUG codes.
- 4.3.4.2.6. The ballasts used in the luminaire shall comply with IEC 61000-3-2, IEC 61347-2-12, IEC 61000-3-3:2001, IEC 61347-1, IEC 61347-2-1, IEC 61347-2-8, IEC 61347-2-9 and IEC 60921 or IEC 60923 as appropriate and be tap selected to the specified operating voltage of the network.
- 4.3.4.2.7. The minimum performance criteria of HPS Luminaire shall be as per Table 4.

Table 4: Minimum Performance Criteria of HPS Luminaire

High Pressure Sodium Lamps	Rated Luminous Efficacy lm/W (100hrs), min	Lumens Lm min	LSF @ 16,000hrs	LLMF @ 16,000hrs	Correlated Color Temp. Tc (K)	Color Rendering (Ra)
150W	90	13,500	0.96	0.94	2000	≥60
250W	90	22,500	0.96	0.94	2000	≥60
400W	90	36,000	0.96	0.94	2000	≥60

Issued by: Head of Section, Standards Development

Authorized by: Head of Department, Standards

Signed:



Signed:



Date: 2015-10-08

Date: 2015-10-08



TITLE: SPECIFICATION FOR STREET LIGHTING ACCESSORIES	Doc. No.	KP1/6C.1/13/TSP/15/002
	Issue No.	2
	Revision No.	3
	Date of Issue	2015-10-08
	Page 22 of 79	

4.3.5. High Pressure Sodium (HPS) Floodlight Luminaires complete with Control Gear

- 4.3.5.1. The High Pressure Sodium (HPS) flood lights units shall be designed manufactured and tested in accordance with IEC 60598-2-5 and shall have all the luminaire qualities described in clause 4.3.1. It shall be of rated voltage/frequency of 220-250V, 50HZ.
- 4.3.5.2. Floodlight luminaires shall be fitted with a porcelain terminal block, earth terminal, cable clamp and lamp holder ready wired to connector block with heat resisting type cable.
- 4.3.5.3. The HPS floodlight luminaires shall be compact in size, attractively styled contemporary design, rugged and dependable, easy to install and service.
- 4.3.5.4. The HPS floodlight luminaires shall have a built-in control gear complete with 400W HPS lamps described in clause 4.4, with a separate one (1)-piece housing for control gear and one (1)-piece lens cover.
- 4.3.5.5. The HPS floodlight luminaires shall be secured by four 6.35mm (1/4") diameter captive stainless steel slotted hex-head bolts.
- 4.3.5.6. The HPS floodlight luminaires shall have thermal shock and impact resistant glass lens sealed with heavy duty, high temperature silicone rubber gasket, firmly seated.
- 4.3.5.7. The HPS floodlight luminaires shall have a heavy duty mogul-base porcelain socket with heavy gauge brass, nickel-plated, double lamp-grip screw shell and spring loaded center contact.
- 4.3.5.8. The HPS floodlight luminaires shall have a compound parabolic, double segment, finished aluminum reflector for optimum efficiency.
- 4.3.5.9. The HPS floodlight luminaires shall be for pole mounting, built-in slip-fitter, for internal wiring, adjustable laterally and vertically, with bronze polyester finish.
- 4.3.5.10. The HPS floodlight luminaires shall have a high pressure aluminium die-cast housing with a high purity anodized hammered finish aluminium reflector
- 4.3.5.11. The HPS floodlight luminaires shall have a frameless thermal resistant tempered glass and a steel mounting bracket coated with epoxy powder

Issued by: Head of Section, Standards Development	Authorized by: Head of Department, Standards
Signed: 	Signed: 
Date: 2015-10-08	Date: 2015-10-08





TITLE:
SPECIFICATION FOR STREET LIGHTING ACCESSORIES

Doc. No.	KP1/6C.1/13/TSP/15/002
Issue No.	2
Revision No.	3
Date of Issue	2015-10-08
Page 23 of 79	

- 4.3.5.12. The ballasts specification shall be as per clause 4.7 and shall be approved for use under the Balancing and Settlement Code (BSC) Unmetered Supplies Arrangements and shall have all necessary UMSUG codes.
- 4.3.5.13. The ballasts shall comply with IEC 61000-3-2, IEC 61347-2-12, IEC 61000-3-3:2001, IEC 61347-1, IEC 61347-2-1, IEC 61347-2-8, IEC 61347-2-9 and IEC 60921 or IEC 60923 as appropriate and be tap selected to the specified operating voltage of the network.

4.4. HIGH PRESSURE SODIUM (HPS) LAMPS;

- 4.4.1. The HPS lamps shall be designed manufactured and tested in accordance with IEC 60662 and shall comply with the safety requirements of IEC 62035 with the HPS Lamp technical characteristics as per Table 5.
- 4.4.2. High pressure sodium (HPS) lamp shall be of the single arc-tube type to ensure the light source is always at the centre of the luminaire optic for consistent photometric performance. Elements within the lamp construction shall not give rise to shadows cast.
- 4.4.3. The HPS lamp shall be so designed that its performance is reliable in normal and accepted use.
- 4.4.4. High pressure sodium lamp shall incorporate a solid state getter with clear lamp bases (getter -blackened lamp bases shall not be accepted).
- 4.4.5. High pressure sodium (HPS) lamp shall be of the single arc-tube type to ensure the light source is always at the centre of the luminaire optic for consistent photometric performance. Elements within the lamp construction shall not give rise to shadows cast.
- 4.4.6. Lamp starting shall be with external ignitor. The circuit connections for lamp starting shall be such that the pulse is applied to the lamp through the eyelet terminal of the cap and with the shell substantially at earth potential.
- 4.4.7. The lamps shall be clear and tubular with the cap on finish of type E39 for 150W lamp and E40 for 250W & 400W and shall comply with IEC 60061-1.
- 4.4.8. The dimensional values for outlines of E40 capped lamps shall as per Table I.2 of IEC 60662 and the dimensional values for outlines of E39 capped lamps shall as per Table I.2 of IEC 60662.
- 4.4.9. Mechanical acceptance of the lamp cap and adjoining part of the lamp neck in the holder shall be ensured by compliance of the lamp with the gauges for testing contact-making as given in IEC 60061-3.

Issued by: Head of Section, Standards Development	Authorized by: Head of Department, Standards
Signed: 	Signed: 
Date: 2015-10-08	Date: 2015-10-08



TITLE:
SPECIFICATION FOR STREET LIGHTING ACCESSORIES

Doc. No.	KP1/6C.1/13/TSP/15/002
Issue No.	2
Revision No.	3
Date of Issue	2015-10-08
Page 24 of 79	

Table 5: HPS Lamp technical characteristics

Sr. No	Particulars	150W	250W	400W
1	Nominal wattage, W	150	250	400
2	Circuit	With external ignitor		
A	Starting and warm-up characteristics - Starting			
1	Test voltage (r.m.s.), V _{max}	198	198	198
2	Starting time, s	5	5	5
3	Pulse characteristics			
4	Height (peak) A, V	2475-2,500	3,300	3,300
5	Width T ₂ at 50 % of A, μs	1.0	2.0	2.0
6	Repetition rate	1/half cycle	1/full cycle	1/full cycle
7	Phase angle, °	60-90	90	90
B	Starting and warm-up characteristics - Warm-up			
1	Test voltage, V	198	198	198
2	Time required to reach 45 V minimum at lamp terminals, min	5	7	7
C	Electrical characteristics			
1	Wattage, W	148	245	380
2	Voltage (r.m.s.) at lamp terminals, V	90	85-115	85-115
3	Current (r.m.s.), A	2.0	2.95	4.5
4	Extinguishing voltage r.m.s., V	111	120	125
D	Photometric characteristics			
1	Correlated colour temperature (nominal), K	-	2,170	2,170
2	Chromaticity co-ordinates x/y (nominal)	-	0.510/0.420	0.510/0.420
3	Colour rendering index Ra (nominal)	-	≥60	≥60

4.5. PHOTO ELECTRIC CELL UNIT (PECU)

4.5.1. General

- 4.5.1.1. All Photo Electric Cell Units (PECUs) shall conform to BS 5972 and be manufactured under the QA System and Procedures of BS 5750, ISO 9002 or EN 29002 with the technical characteristics as per Table 6.
- 4.5.1.2. All PECU shall be suitable for mounting at 5m and/or 6m and be of the miniature type fitted to the lantern with conduit thread fixing.
- 4.5.1.3. All PECU shall be guaranteed for a minimum life of 6 years from the date of manufacture and this date shall be clearly marked on the unit.

Issued by: Head of Section, Standards Development	Authorized by: Head of Department, Standards
Signed:	Signed:
Date: 2015-10-08	Date: 2015-10-08



TITLE:
SPECIFICATION FOR STREET LIGHTING ACCESSORIES

Doc. No.	KP1/6C.1/13/TSP/15/002
Issue No.	2
Revision No.	3
Date of Issue	2015-10-08
Page 25 of 79	

4.5.1.4. All PECU shall provide Class 2 protection against electric shock, with a minimum enclosure protection rating of IP65 to IEC60529.

4.5.1.5. The PECU shall be classified in the following classes:

4.5.2. Type I – Ordinary PECU

4.5.2.1. Type I PECU shall operate on 220V- 250V 50Hz AC and shall be capable of switching discharge lighting load of upto1000W high pressure sodium lamps or upto 400W LED luminaires with a pre-set switch on/off level of 35/18 lux and a negative switching differential of 1:0.5.

4.5.2.2. Type I PECU shall incorporate a time delay circuit to ensure lamps are not switched on by transient changes of illuminance; the delay shall be between 15 and 30 seconds.

4.5.2.3. Type I PECU shall be designed to fail in the ON position, such that in the event of a fault in the cell, the controlled lights will switch on.

4.5.2.4. Type I PECU shall be switched by a relay assisted a triac or a synchronous switch method and be fully solid state with switching activated by a filtered silicon photo diode to match the CIE photopic response. A method of ensuring that the load remains switched to the on state must be provided in the event of an overload destroying the device.

4.5.2.5. Type I PECU shall have zero drift over its guaranteed life, have a power consumption not exceeding 0.5W under load conditions and be capable of operating within a temperature range of -20°C to +80°C, comply with European EMC Emission Directives and conform to BS 2011 in respect to vibration.

4.5.2.6. Photoelectric control shall fit an EEI/NEMA standard 3-terminal polarized twist lock type receptacle and shall be furnished complete with a neoprene receptacle gasket.

4.5.2.7. Photo-electric controllers must be manufactured using non-hazardous materials

4.5.2.8. All units must be indelibly marked with the switch setting, the manufacturer's identification mark, model number and the date of installation.

Issued by: Head of Section, Standards Development	Authorized by: Head of Department, Standards
Signed:	Signed:
Date: 2015-10-08	Date: 2015-10-08

Table 6: Photo Electric Cell Units (PECUs) technical characteristics

Sr. No	Parameter	Specification
1	Operating Voltage	220-240V, 50Hz
2	Current rating	16 A
3	Contacts	Single-pole/single-throw; normally closed at night
4	Contact load rating	1000 Watts incandescent; 1800 VA H.I.D
5	Surge Protection	Expulsion or Metal-Oxide-Varistor type arrestor
6	Turn-on level	1.0-1.5 lumens
7	Turn-on to Turn-off ratio	1:2- 1:5
8	Temperature range	-20°C to +80°C.

4.5.3. Type II – PECU complete with a Timer Switch

4.5.3.1. General

4.5.3.1.1. Type II PECU shall be complete with a timer switch suitable for direct installation in single-phase AC supply operated a voltage range of 180 to 290V AC and shall be able to withstand a fault voltage of upto 440 VAC. Its application shall include - Compound / Yard Lighting, Street Lighting, Elevation Lighting, Landscape Lighting, Gardens, Aviation Lighting etc.

4.5.3.1.2. The terminals provision for connection to LIVE IN, NEUTRAL and LIVE OUT shall be properly enclosed in such a way that no live part is open.

4.5.3.1.3. The switch must have an endurance of at least 5,000 cycles at full rated load, an ambient temperature range of -1 °C to +40 °C and shall perform in open air with RH upto 95% at 25 °C.



4.5.3.1.4. The internal clock shall be quartz based for long-term stability. Input mains power failure will not stop the clock since it shall be equipped with a rechargeable battery. The switching OFF will take place as per user selection instead of at DAWN.

4.5.3.2. Features

Type II PECU shall have the following features:

a) Optical Sensor

- (i) The sensor used should be reliable for calibration stability
- (ii) The sensing circuit should be sealed in a container meeting IP 54

Issued by: Head of Section, Standards Development	Authorized by: Head of Department, Standards
Signed: 	Signed: 
Date: 2015-10-08	Date: 2015-10-08



TITLE:
SPECIFICATION FOR STREET LIGHTING ACCESSORIES

Doc. No.	KP1/6C.1/13/TSP/15/002
Issue No.	2
Revision No.	3
Date of Issue	2015-10-08
Page 27 of 79	

(iii) The sensor should be located behind a vertical wall to avoid accumulation of dust etc.

b) Auto Over Load Trip And Latch Mechanism

Type II PECU shall be equipped a switch with Electronic over Current Trip and Latch Mechanism, LED Flashes as an indication of this state and Electrical reset which restart the switch according to the following steps are:

- (i) Switch OFF the mains, and
- (ii) Remove overload, and
- (iii) Switch ON the mains

c) Auto Over/Low Voltage Trip And Reset

These shall consist of the following functionalities:

- (i) Auto over voltage trip - >270 VAC
- (ii) Auto Over voltage Reset - < 250 VAC
- (iii) Auto Low Voltage Trip - <150 VAC
- (iv) Auto Low Voltage Reset - >165 VAC

4.5.3.3. Additional Features

- (i) Automatic switch ON at DUSK.
- (ii) Automatic switch OFF at DAWN.
- (iii) Immunity to dust, bird sittings and cloud cover.
- (iv) Immunity to moon and other street light.
- (v) Switch OFF selection from 4-8 hrs or at DAWN.
- (vi) Override facility for ON and Continuous OFF

4.5.3.4. Operational specifications Shall include:

- a) Operating Voltage – 220 - 250VAC +10% 50 Hz
- b) Recommended Lighting Load - upto 3000 watts
- c) Maximum Continuous Current - 16A
- d) Illuminance for Switching ON - <60 lux for >30 seconds
- e) Illuminance for Switching OFF:
 - (i) In Field - >10 lux for >30 seconds
 - (ii) In Lab - >60 lux for >30 seconds
- f) Resolution for ON Duration - 4 to 8 hours with ½ hour steps

Issued by: Head of Section, Standards Development

Authorized by: Head of Department, Standards

Signed:

Signed:

Date: 2015-10-08

Date: 2015-10-08



TITLE: SPECIFICATION FOR STREET LIGHTING ACCESSORIES	Doc. No.	KP1/6C.1/13/TSP/15/002
	Issue No.	2
	Revision No.	3
	Date of Issue	2015-10-08
	Page 28 of 79	

4.5.4. Type III – GSM enabled PECU complete with Timer Switch for Outdoor Lighting

4.5.4.1. Design and construction

4.5.4.1.1. Type III PECU shall be complete with a timer switch and GSM enabled suitable for direct installation in single-phase AC supply operated a voltage range of 180 to 290V AC and shall be able to withstand a fault voltage of upto 440 VAC. Its application shall include - Compound / Yard Lighting, Street Lighting, Elevation Lighting, Landscape Lighting, Gardens, Aviation Lighting etc.

4.5.4.1.2. It shall be suitable for switching of indoor and outdoor lighting systems remotely using an SMS from your mobile handset to turn ON/OFF, set timings or else the device can operate independently. Type III PECU shall be equipped with sun based, time based, and combination of sun and time settings.

4.5.4.1.3. The terminals provision for connection to LIVE IN, NEUTRAL and LIVE OUT shall be properly enclosed in such a way that no live part is open.

4.5.4.1.4. The switch must have an endurance of at least 5,000 cycles at full rated load, an ambient temperature range of -10 °C to +60°C and shall perform in open air with RH upto 95% at 25 °C.

4.5.4.2. Design Features and Operational Characteristics

4.5.4.2.1. It shall consist of the following modular components:

a) Optical sensor:

- (i) The sensor used should be reliable for calibration stability
- (ii) The sensing circuit should be sealed in a container meeting IP 65
- (iii) The sensor should be located behind a vertical wall to avoid accumulation of dust etc.

b) Communication Unit (GSM MODULE)

- (i) Module – SIM 900
- (ii) Quad-Band 850/ 900/ 1800/ 1900 MHz
- (iii) Operation temperature: -30 °C to +80 °C

4.5.4.2.2. Operational specifications shall be as follows:

- (i) Operating Voltage - 230VAC +10% 50 Hz
- (ii) Recommended Lighting Load - Up to 3000 watts
- (iii) Maximum Continuous Current - 16A
- (iv) Illuminance for Switching ON - <60 lux for >30 seconds

Issued by: Head of Section, Standards Development	Authorized by: Head of Department, Standards
Signed:	Signed:
Date: 2015-10-08	Date: 2015-10-08



TITLE:
SPECIFICATION FOR STREET LIGHTING ACCESSORIES

Doc. No.	KP1/6C.1/13/TSP/15/002
Issue No.	2
Revision No.	3
Date of Issue	2015-10-08
Page 29 of 79	

(v) Illuminance for Switching OFF:

- In Field - >10 lux for >30 seconds
- In Lab - >60 lux for >30 seconds

4.5.4.2.3. Type III PECU shall have an optional provision for:

- (i) Manual ON/OFF switching
- (ii) Automatic switching.

4.5.4.2.4. The automatic switching operations shall be based on:

- (i) Sun based operation (On at Sunset, Off at Sunrise)
- (ii) Time based operation
 - Single On/Off Cycle
 - Double On/Off Cycle
 - Triple On/Off Cycle
- (iii) Combination of Sun and Time based operation
 - On at Sunset-Off at Time
 - On at Time-Off at Sunrise
 - On at Sunset-Off at Time- On at Time off at Sunrise

4.5.4.2.5. Type III PECU shall also have an Auto Over/Low Voltage Trip And Reset with the following functionalities;

- (i) Auto Over Voltage Trip - >280 VAC
- (ii) Auto Over Voltage Reset - < 265 VAC
- (iii) Auto Low Voltage Trip - <150 VAC
- (iv) Auto Low Voltage Reset - >165 VAC

4.6. TIMERS FOR STREET LIGHTING

4.6.1. Design

- 4.6.1.1. The timer for street lighting shall be a digital-type timer rated 220 - 240V AC, 50Hz in single frame of size capable of carrying a load of 6 kW to 12 kW manufactured to IEC60439-3.
- 4.6.1.2. The timers shall be of type 50Hz net-synchronization or type quartz control with a self-power reserve to secure the time setting and program storage in case a power interruption does occur.
- 4.6.1.3. The timers shall allow one to set the ON and OFF time. The switching of street lights shall be repeated every day as per the set time through Programmable 24

Issued by: Head of Section, Standards Development

Authorized by: Head of Department, Standards

Signed:

Signed:

Date: 2015-10-08

Date: 2015-10-08



TITLE:
SPECIFICATION FOR STREET LIGHTING ACCESSORIES

Doc. No.	KP1/6C.1/13/TSP/15/002
Issue No.	2
Revision No.	3
Date of Issue	2015-10-08
Page 30 of 79	

hours' Time Switch / Programmable Astronomical Time Switch. The program shall consist of a closing time and an opening time for a circuit.

- 4.6.1.4. The timers shall have a Programmable Time Switch (PTS) that shall automatically adjust the set time along with seasonal variation to control ON /OFF for lighting on purpose of realizing that light is turned ON when sun sets & turned OFF when sun rises. This time switch is programmed on latitude base for whole year for sun rise and sun set timing.
- 4.6.1.5. The timer selection mode shall be by Auto or Manual Selector switch
- 4.6.1.6. The timers shall be for wall mounting on cubicles and shall be pre-wired ready for use
- 4.6.1.7. The technical characteristics (depending on type) of the timers shall be:
 - a) Modular design.
 - b) Time adjustment by 50 Hz net, quartz.
 - c) Maximum two (2) channel output.
 - d) Manual override switching function.
 - e) Power reserve for all quartz and DCF controlled timers.



4.6.2. Features

The following features shall be present:

- a) Easily programmable on front of device.
- b) Computer aided programming software available.
- c) Compact 18 mm design for restricted space opportunities.
- d) Separate IP40 covers are available for direct wall mounting.
- e) High level of accuracy.
- f) Maximum lamp load test data for reference.
- g) Automatic summer and winter time adjustment.
- h) Holiday & Random program settings.
- i) High power reserve up to 10 years.

Table 7: Timers For Street Lighting technical characteristics

Particular	Ratings.
Operating Voltage	220 - 240 Vac
Program Fuctions	ON / OFF
Number of Memory Locations	48
Power Reserve	150 Hrs
Max. Switching Capacity at 250 VAC $\cos\Phi = 1$	16 A
Max. Switching Capacity at 250 VAC $\cos\Phi = 0.6$	10 A
Incandescent / Halogen Lamps	2300 watt
Shortest Switching Time	15 Min

Issued by: Head of Section, Standards Development	Authorized by: Head of Department, Standards
Signed: 	Signed: 
Date: 2015-10-08	Date: 2015-10-08





TITLE:
**SPECIFICATION FOR STREET
LIGHTING ACCESSORIES**

Doc. No.	KP1/6C.1/13/TSP/15/002
Issue No.	2
Revision No.	3
Date of Issue	2015-10-08
Page 31 of 79	

4.7. HIGH INTENSITY DISCHARGE BALLASTS

- 4.7.1. Ballasts shall comply with IEC 61000-3-2, IEC 61347-2-12, IEC 61000-3- 3, IEC 61347-1, IEC 61347-2-1, IEC 61347-2-8, IEC 61347-2-9 and IEC 60921 or IEC 60923 as appropriate and be tap selected to the specified operating voltage of the network.
- 4.7.2. Ballasts shall bear the CE Mark and wiring connection type on the casing and shall also be approved for use under the Balancing and Settlement Code (BSC) Unmetered Supplies Arrangements and shall have all necessary UMSUG codes.
- 4.7.3. Ballasts shall be vacuum-pressure impregnated with a silica-filled polyester varnish to re-enforce the electrical insulation, preclude moisture, inhibit noise, and dissipate heat. The process of vacuum impregnation shall be such that the interstices of the windings are completely filled with the impregnating material.
- 4.7.4. Connections shall be brought out to a suitable brass screw terminal block mounted on the ballast housing. Terminal blocks with steel screws will not be acceptable.
- 4.7.5. The HID ballasts shall be constructed in such a manner that the lamination is engaged within a galvanized steel standard and the insulation system shall be rated class H (180°C maximum coil hot spot temp.)
- 4.7.6. The bidders shall provide the HID ballasts characteristic curves to support their offers during tender in accordance with IEC 60662.
- 4.7.7. The HID ballasts shall date stamped on either the top surface or the side surface of the ballast core.
- 4.7.8. The HID ballasts shall be component recognized by the UL (underwriter's Laboratory) and shall meet the 88% efficiency requirements of EISA (ACT, 2007).
- 4.7.9. The ballast shall be matched to the actual supply voltage within 2.5 % of this voltage in order to obtain optimum performance regarding colour characteristics and life as per Table 8.
- 4.7.10. The ballasts connection shall be a constant wattage autotransformer with the following electrical characteristics as per Table 8 and shall be capable of operating capable of operating lamps of the following wattage range - 150W, 250W and 400W as described in clause 4.4..

Issued by: Head of Section, Standards Development	Authorized by: Head of Department, Standards
Signed: 	Signed: 
Date: 2015-10-08	Date: 2015-10-08



TITLE:
SPECIFICATION FOR STREET LIGHTING ACCESSORIES

Doc. No.	KP1/6C.1/13/TSP/15/002
Issue No.	2
Revision No.	3
Date of Issue	2015-10-08
Page 32 of 79	

Table 8: Characteristics of ballasts

Sr. No	Characteristics	Ratings		
		150	250	400
1	Nominal lamp wattage	150	250	400
2	Frequency, Hz	50	50	50
3	Rated voltage, V	200	220	220
4	Calibration current, A	2.0	3.0	4.6
5	Voltage/current ratio	81.0 ± 0.5%	60.0	39
6	Power factor	0.060±0.010	0.06±0.005	0.06±0.005
7	Pulse width	2.0-3.6	3.0-5.2	4.6-7.5
8	Lamp warm-up current (r.m.s.), A	2,700-4,500	<5,000	<5,000
9	Pulse height (peak), luminaire requirement, V	10	10	12
10	Temperature rise	180	180	180

4.8. CAPACITORS FOR LUMINAIRES

- 4.8.1. Capacitors shall comply with IEC 61048 and IEC 61049 and shall bear the CE mark and fully capable for use in HPS lamps rated 150W, 250W and 400W as described in clause 4.4.
- 4.8.2. Capacitors shall only be connected to the primary (line) side of transformer ballasts. After connection of the power factor correction capacitor, the power factor shall not be less than 0.88 (lagging).
- 4.8.3. All capacitors shall be fully encapsulated and filled with self-extinguishing resin.
- 4.8.4. The capacitors shall be of the ratings shown in the table below for the corresponding High Pressure Sodium lamps
- 4.8.5. The characteristics of capacitors shall be as per Table 9.

Table 9: Technical characteristics of capacitors for Luminaires

Lamp		Capacitor µF± 5%
Wattage	Current	
150	1.8	21
250	3.0	33
400	4.4	45

4.9. IGNITORS FOR LUMINAIRES

- 4.9.1. Ignitors shall comply with IEC 60926 and IEC 60927 and shall bear the CE mark. Ignitors shall be of the superimposed-pulse solid-state electronic trigger type.

Issued by: Head of Section, Standards Development	Authorized by: Head of Department, Standards
Signed:	Signed:
Date: 2015-10-08	Date: 2015-10-08

- 4.9.2. The ignitors shall be capable of operating lamps of the following wattage range - 150W, 250W and 400W in clause 4.4.
- 4.9.3. Ignitors shall be of the standard type to allow striking of the lamp without switching the power off after replacement of a faulty ignitor.
- 4.9.4. Ignitors shall be suitable for operating any make of lamp in conjunction with any make of ballast at temperatures up to 90° C. The ignitor shall be connected in series with the ballast and installed between the ballast and lamp holder. Systems that operate with the ignitor in parallel with the lamp, or with special tapped ballasts, will not be acceptable.
- 4.9.5. All ignitors shall be suitable for connection in the circuit so that the ignition pulse is confined between the ignitor and lamp holder.
- 4.9.6. The ignitors shall conform to the following electrical characteristics as per Table 10.

Table 10: Ignitor characteristics

Sr. No.	Characteristics	Ratings		
1	Lamp wattage , W	150,	250	400
2	Switch on voltage , V	≤ 200		
3	Switching off voltage, V	> 168		
4	Voltage peak, kV	3.4		
5	Load capacitance, pF	155		
6	Losses at peak current of 4.5A , W	2.7		
7	Pulse width	2.0-3.6	3.0-5.2	4.6-7.5
8	Lamp warm-up current (r.m.s.), A	2,700-4,500	<5,000	<5,000
9	Pulse height (peak), luminaire requirement, V	10	10	12

4.10. MINIATURE CIRCUIT BREAKERS

4.10.1. The miniature circuit breakers shall be C-type ac. air-break circuit-breakers for operation at 50 Hz having a rated voltage not exceeding 250 V (between phases), a rated current not exceeding 63 A and a rated short-circuit capacity not exceeding 10,000 A designed, manufactured and tested in accordance with IEC 60898-1 for street-lighting application.

4.10.2. The MCB electrical and mechanical characteristics shall be as per Table 11.

Issued by: Head of Section, Standards Development

Authorized by: Head of Department, Standards

Signed:



Signed:



Date: 2015-10-08

Date: 2015-10-08

Table 10: MCB for streetlighting characteristics

Property	Requirement
Number of poles	Two (2) Pole Single Throw snap-action
Protection against external influences	Enclosed type
Method of mounting	Panel board type
Method of connection	Screw-in type
Value of rated operational voltage	220 – 250V AC
Value of rated current	10A, 16A, 25A, 32A, 40A and 63A
Value of rated frequency	50 Hz
Range of instantaneous tripping current	Above 5In upto and including 10In
Value of rated short-circuit capacity	10 kA
I ² t characteristic	Attach the characteristic curve
I ² t classification	
Endurance	Exceeds 10,000 trippings at 200% rated load
Insulation Resistance	100 MΩ
Ambient temperature	0...+50 °C

4.11. CONSUMER UNIT (CU)

- 4.11.1. The consumer unit shall be manufactured in accordance with IEC 61439-1 and IEC 61439-3. The consumer unit shall be rated voltage is under or equal to 600/1000V AC 50Hz or 1500 V DC.
- 4.11.2. The consumer unit will be factory assembled (with the exception of miniature circuit breakers) and shall comply with the requirements of IEC 60439-3.
- 4.11.3. The consumer unit shall have a 6 number of outgoing ways with 6 spare ways suitable for fitting MCBs, contactors etc.
- 4.11.4. It shall be fitted with main controlling double pole (DP) isolator switch rated at no less than 63 Amps mounted on DIN rails with spare space on DIN rail for mounting the circuit breakers and contactors.
- 4.11.5. The various circuits shall be arranged to comply with the requirements of the latest IEE wiring Regulations (BS 7671:2008).
- 4.11.6. The unit shall be complete with blanking plates, bus-bars, bus-bar cover, terminal bars, and installation instructions. The bus-bars shall be of high purity copper material.
- 4.11.7. The consumer unit shall be of flash mounting type and suitable for outdoor installation inside a street-lighting control pillar.
- 4.11.8. The consumer unit shall comply with the following technical requirements as per Table 12.

Issued by: Head of Section, Standards Development

Authorized by: Head of Department, Standards

Signed:



Signed:



Date: 2015-10-08

Date: 2015-10-08



TITLE:
SPECIFICATION FOR STREET LIGHTING ACCESSORIES

Doc. No.	KP1/6C.1/13/TSP/15/002
Issue No.	2
Revision No.	3
Date of Issue	2015-10-08
Page 35 of 79	

Table 12: Technical requirements on Consumer Units

Sr. No.	Description	Requirement
1	Standard of manufacture	IEC 61439-1 & 3
2	Max load/ No of ways	100A, 6-Way SPN
	Maximum voltage	220-250 V AC , 50Hz
3	Degree of protection	IP 46
4	Enclosure material	Aluzinc steel sheet or galvanized steel
5	Steel thickness – Box and cover	1 mm
6	Knock-outs - body	Top, bottom and rear
6	Enclosure finish	Gray, RAL 7035 Polyester epoxy powder paint
7	Paint thickness	60-80 microns
8	Incomer	Switch isolator, 63A RCCBO (see clause 4.11) , Frame size 63A : 50mm ²
9	Neutral terminal bar	16mm ²
10	Earth terminal bar	16mm ²
11	Minimum clearances in air	Phase to phase -25.4mm Phase to earth -25.4mm
13	Minimum creepage distances	Phase to phase -50.8mm Phase to earth -25.4mm
15	EMC requirements	Performance requirements criteria for environment class A as per Table J.1 of IEC 61439
16	Rated power frequency withstand	AC - 2 kVrms / 5s DC – 2.83 kV
18	Rated impulse voltage	2.5 kV peak
19	Short circuit withstand capacity	10kA/1s
20	Approximate dimension (H x W x D) mm	256 x 368 x 110 mm

4.12. EARTH LEAKAGE CIRCUIT BREAKER

4.12.1. Design

4.12.1.1. The Earth Leakage Circuit Breaker (ELCB) shall be current operated with a sensitivity of 30mA and shall conform to IEC 61008 and BS 4293.

4.12.1.2. The ELCB shall incorporate a residual current operated electromagnetic release which operates without any auxiliary source of supply to open a circuit automatically in the case of an earth leakage fault between phase and earth greater than or equal to $I\Delta n$.

Issued by: Head of Section, Standards Development	Authorized by: Head of Department, Standards
Signed:	Signed:
Date: 2015-10-08	Date: 2015-10-08

- 4.12.1.3. The ELCB shall operate and switch off the circuit within 30 milliseconds in case of a fault.
- 4.12.1.4. The ELCB shall be suitable for the circuit of 50Hz, rated voltage 230/400V, and rated current at least 40Amps.

4.12.2. Features

The ELCB shall have the following features;

- a) Overload, short circuit and over voltage protect functions.
- b) Electrical distribution system to prevent electric shock.
- c) A trip free mechanism that operate even on neutral failure.
- d) A test button to simulate leakage and to test the ELCB.

4.12.3. The characteristic performance of ELCB shall be as per Table 13.

Table 13: Technical characteristics of ELCB

No.	Sr.	Particulars	Requirements
1		Number of Poles	1P+N
2		Rated Current(A)	40
3		Rated Residual Operating Current(I n)(mA)	30
4		Rated Residual Non-operation Current(I no)(mA)	0.5IΔ n
5		Rated Voltage(V)	230/400
6		Residual Current Off-time	0.1S
7		Short Circuit Capacity(Icu)	3000A
8		Mechanical Endurance	4000
9		Tripping Curve	C,D
10		Degree of protection	IP20

4.13. LIGHTING CONTACTORS

4.13.1. General construction and performance requirements

- 4.13.1.1. The contactor shall be two-pole contactors on single-phase a.c designed and manufactured in accordance with IEC 61095 and IEC 60947-4-1 standards. The contactor shall be suitable for switching of lamp loads in both utility as well as industrial areas.

Issued by: Head of Section, Standards Development	Authorized by: Head of Department, Standards
Signed: 	Signed: 
Date: 2015-10-08	Date: 2015-10-08



TITLE:
SPECIFICATION FOR STREET LIGHTING ACCESSORIES

Doc. No.	KP1/6C.1/13/TSP/15/002
Issue No.	2
Revision No.	3
Date of Issue	2015-10-08
Page 37 of 79	

- 4.13.1.2. The contactor shall be very specific due to the applied operating coil and the construction of the main contacts. They shall be designed with AC coils to ensure silent operation and enhanced low power consumption.
- 4.13.1.3. The contactor with its enclosure shall be designed and constructed to withstand the stresses occurring during installation and normal use and, in addition, shall provide a specified degree of resistance to abnormal heat and fire as per clause 8.1 of IEC 61095.
- 4.13.1.4. The moving contacts of the contactors intended to make and break together shall be so mechanically coupled that all poles make and break substantially together whether operated manually or automatically.
- 4.13.1.5. The contactors shall close satisfactorily at any value between 85 % and 110 % of their rated control supply voltage U_s . Where a range is declared, 85 % shall apply to the lower value and 110 % to the higher as per clause 8.2 of IEC 61095
- 4.13.1.6. The contactors shall offer optimal contacts and low heat dissipation to guarantee a long lifetime and a wide range of characteristics.
- 4.13.1.7. The bidder shall provide the relevant electrical durability curves to support the offer.

4.13.2. Features

The following features shall be part of the design of the lighting contactors:

- a) It shall be an AC current operated type rated 25, 40A and 63A with double-pole and tripple pole contacts and optional add-on auxiliary contact.
- b) The coil voltages shall be at least 220 - 250V ac
- c) Shall have a DIN modular profile.
- d) Spacers available to extend lifetime (it is recommended to use 1 spacer between every 2 contactors installed).
- e) Day/night operation with manual override function.
- f) Low inrush power for all ac types.
- g) Integral contact indication.

4.13.3. Ratings

The contactor shall be suitably rated for operating lighting circuits of luminaires rated 150W, 200W and 400W respectively and shall be rated as per Table 14.

Issued by: Head of Section, Standards Development

Authorized by: Head of Department, Standards

Signed:

Signed:

Date: 2015-10-08

Date: 2015-10-08



TITLE:
SPECIFICATION FOR STREET LIGHTING ACCESSORIES

Doc. No.	KP1/6C.1/13/TSP/15/002
Issue No.	2
Revision No.	3
Date of Issue	2015-10-08
Page 38 of 79	

Table 14: Technical parameters for lighting contactors

No	Description	Requirements		
		25A	40A	63A
1	Current rating,	25A	40A	63A
2	Type (<i>To be declared during tender</i>)	AC operated double or triple pole		
3	Utilization category	AC-1/AC-7a		
4	Rated operational voltage U _{max}	600V		
5	Rated frequency, Hz	50		
6	Rated insulation voltage, kVrms	2,500V for 1s as per Table 19 of IEC 61095		
7	Rated operational current –AC1/AC7a	25A	40A	63 A
8	Impulse withstand voltage, kVpk	4 kV/s as per Table F.1 of IEC 61095		
9	Rated making/breaking capacity, I _c / I _e = 1.5, A	35.7	60	94.5
10	Maximum breaking capacity, A	250A		
11	Short circuit current, kA	3 kA as per Table 21 of IEC 61095		
12	Associated protection MCB	25A-6kA	40A-10kA	63A-10kA
13	Maximum electrical switching frequency for AC-1/AC-7a,	300 cycles/h as per clause 5.3.4.2 of IEC 61095		
14	Coil operating limits as per IEC 60947-4-1	0.85...1.1xU _c (at Ø≤55C		
15	Heat dissipation per pole, W	1.5	3.2	6
16	Electrical durability, cycles	1,500,000		
17	Mechanical durability, operating cycles	1,000,000		
18	Degree of enclosure	IP 20		
19	Air temperature close to contactor, °C	-25 to +55		
20	Climatic withstand	According to IEC 60082-2-30		

4.13.4. Markings

4.13.4.1. The following indelible and easily legible mandatory markings shall be made on the contactor, preferably on the nameplate if any, to enable complete data to be obtained from the manufacturer.

- a) Marking of the manufacturer's name or trade mark and
- b) Type designation or serial number shall be mandatory.

4.13.4.2. The following information shall also be marked and visible after mounting:

- a) Direction of movement of the actuator
- b) Indication of the position of the actuator;
- c) Approval or certification mark, if applicable;
- d) Terminal identification and marking ;
- e) IP code and class of protection against electric shock.

Issued by: Head of Section, Standards Development	Authorized by: Head of Department, Standards
Signed:	Signed:
Date: 2015-10-08	Date: 2015-10-08



TITLE:
SPECIFICATION FOR STREET LIGHTING ACCESSORIES



Doc. No.	KP1/6C.1/13/TSP/15/002
Issue No.	2
Revision No.	3
Date of Issue	2015-10-08
Page 39 of 79	

4.14. CLEAR CUT OUTS AND ISOLATORS.

- 4.14.1. All cut-outs shall be clear and incorporate a double pole isolation switch complying with BS 5419 having a rating of 32 Amps, 63 Amps and 100Amps with adequate short circuit withstand for the position in the circuit in which it is installed.
- 4.14.2. The isolation switch shall be capable of being positively and visibly locked off by means of a padlock or locking bar and it shall not be possible to remove the outgoing fuse(s) unless the isolation switch is in the off position.
- 4.14.3. The cut-outs shall be of the all insulated type with drip proof enclosure affording a minimum degree of protection to IP22 as per IEC 60529 and have a high mechanical and a dielectric strength of 6 kV. The terminals shall be capable of accepting conductors with crimped lug connectors.
- 4.14.4. The incoming phase terminals shall be shrouded when all connections have been made, the shroud shall be capable of removal for inspection or disconnection of cable ends, but shall not be capable of accidental detachment or be of a push fit type. Movement of cables shall be prevented by the use of bushes or inserts. Fuse carriers shall utilize HRC fuse links to BS 88.
- 4.14.5. The units shall be provided with separate terminals for phase and neutral conductors manufactured from solid brass and electro-tinned and are entirely suitable for connecting the requisite cables.
- 4.14.6. Where connection is made into any cut-out for supplying a sub-circuit the cut-out shall incorporate a second fuse link to protect the sub-circuit.
- 4.14.7. The cut-outs shall be securely fitted to the baseboard with non-corrodible screw fixings.

4.15. FUSES

- 4.15.1. The fuses in specification shall conform to IEC 60269, BS 88 and KP1/3CB/TSP/11/022 and this specification.
- 4.15.2. No rewirable fuses shall be used. All fuses to be HRC to BS 88 Part 2 operating on 240 volts 50Hz supply. Fuse ratings shall be 6 amps for lamps up to and including 100W and 10A for lamps greater than 100W.

Issued by: Head of Section, Standards Development	Authorized by: Head of Department, Standards
Signed: 	Signed: 
Date: 2015-10-08	Date: 2015-10-08



TITLE:
SPECIFICATION FOR STREET LIGHTING ACCESSORIES

Doc. No.	KP1/6C.1/13/TSP/15/002
Issue No.	2
Revision No.	3
Date of Issue	2015-10-08
Page 40 of 79	

4.16. CABLES

- 4.16.1. The cables in this specification shall conform to IEC 60228, BS 6004, KS 04-194 and KP1/3CB/TSP/05/016 for 1.5mm² and 2.5mm², KS 04-187 and KP1/3CB/TSP/05/032 for 6mm² PVC SWA cable.
- 4.16.2. Underground cables shall consist of stranded copper conductors, PVC extruded bedding, a concentric layer of steel wire armour, overall PVC sheathing suitable for operation in an earthed system and of rated voltage 600/1000 volts at 50Hz, all in accordance with BS 6346 for metric cable.
- 4.16.3. All luminaires shall be delivered pre-wired with 8m of 1.5 mm² - 3 core arcticflex: 16.16 Standards: BS7919 Table 44, VDE281.
- 4.16.4. The conductor shall be Class 5 flexible plain copper conductors to IEC 60228 size 2 x 1.5mm² and size 2.5mm² with earth but shall be class 2 for armoured 2-core cables in accordance with IEC 60228.
- 4.16.5. All armoured cable cores shall be of equal cross sectional area of 6 mm² minimum and be of such a size that the requirements of the current IEE Wiring Regulation, BS 7671, are met and allow for a disconnection time not exceeding 5 seconds.
- 4.16.6. Internal wiring between the terminal block in the lantern and the components in the base of the column shall be PVC insulated and sheathed cable of 300/500V grade, have a copper conductor size of not less than 2.5 mm².
- 4.16.7. Where approved, cable to a two part photo electric cell detector unit shall be 1.5 mm² two (2)-core flat with white sheath.
- 4.16.8. All cores shall be correctly colour coded and cables for continuous earth bonding shall be green/yellow PVC insulated single core copper cable of minimum cross section 6 mm² PVC SWA cable rated 600/1000V grade conforming to BS 6004 and KS 04-1122.

4.17. CONTROL PILLARS

4.17.1. General

- 4.17.1.1. The control pillars shall be designed and manufactured in accordance with IEC 61439-1 and IEC 61439-3.
- 4.17.1.2. The pillar shall be constructed from not less than 2mm thick galvanized mild steel with the minimum galvanization thickness of 85µm in accordance with ISO 1461,

Issued by: Head of Section, Standards Development

Authorized by: Head of Department, Standards

Signed:

Signed:

Date: 2015-10-08

Date: 2015-10-08

TITLE:
SPECIFICATION FOR STREET LIGHTING ACCESSORIES

Doc. No.	KP1/6C.1/13/TSP/15/002
Issue No.	2
Revision No.	3
Date of Issue	2015-10-08
Page 41 of 79	

and a further treatment of the galvanized surface by degreasing and left with a smooth finish to prepare for painting.

- 4.17.1.3. The control pillar shall be equipped with a 12-way mounting rails and shall be rated 200A for surface mounted and 125A for pole mounted designs. The normal rating shall be at a maximum temperature of 40°C.
- 4.17.1.4. The pillar shall be sealed to minimum IP65 on the doors and IP45 on the vent louvres. They shall include a full size backboard of varnished marine plywood at least 15mm thick or other approved non-hygroscopic material. Alternatively, a purpose-designed equipment mounting system may be used.
- 4.17.1.5. The pillar design shall include a double door (surface mounted) and single door (pole mounted) and shall be fitted with tamper-proof "O locks", all locks being identical in pattern. The locking mechanism shall be lubricated with grease immediately following installation. Two sets of keys shall be provided to the Chief Engineer - Street Lighting prior to the adoption of the installation. All doors are to be provided with an earthing strap.
- 4.17.1.6. The ventilation shall be provided to prevent the build-up of condensation and in such cases the control pillar shall be protected by vermin proof screens.

4.17.2. Ground mounted (GM) control pillars

- 4.17.2.1. The GM control pillars shall be suitable for mounting on a 250mm thick foundation of concrete ST2 mix complying with BS 5328 – 1:1997. They shall be rooted or provided with fixing bolts to enable the unit to be securely located. The entry for cables shall be via the root.
- 4.17.2.2. The control pillars shall be a minimum of 1350mm x 1200mm x 450mm (H x W x D) raised to a height of 400mm and overall height of 1750mm. It shall have a backboard dimension of approximately 1170mm x 980mm (H x W) with a working area of at least 420mm.
- 4.17.2.3. This shall be sufficient to accommodate:
 - a) The incoming supply cable including cut-out.
 - b) A lockable double pole isolator [if not included in the cut-out].
 - c) Any contactor and/or photocell relay.
 - d) A distribution board for all highways electrical feeds including sufficient spare capacity to accommodate at least one extra circuit.
 - e) All necessary fuses.
 - f) At least 25% spare space on the backboard upon completion.

Issued by: Head of Section, Standards Development	Authorized by: Head of Department, Standards
Signed: 	Signed: 
Date: 2015-10-08	Date: 2015-10-08



TITLE:
SPECIFICATION FOR STREET LIGHTING ACCESSORIES

Doc. No.	KP1/6C.1/13/TSP/15/002
Issue No.	2
Revision No.	3
Date of Issue	2015-10-08
Page 42 of 79	

- g) Heater
- h) RCD (Residual Current Device)
- i) Interior light
- j) 13A Socket

- 4.17.2.4. Distribution fuse boards shall be of the HRC type provided with an external earth, phase barrier and colour coded (red-phase; black-earth). They shall be fitted with the same number of live and neutral bus bar terminals as there are outgoing circuits plus at least one spare way.
- 4.17.2.5. A circuit diagram and labeling showing details of interconnection of equipment and the connection of cables to and from the pillar, all indelibly drawn or engraved on a material not subject to damage by the environment or normal use, shall be securely fixed internally to each feeder pillar after completion of the installation.
- 4.17.2.6. An earthing system shall be provided in each control pillar. It shall accept the incoming earth facility from the supply authority onto an earthing bar or terminal strip and interconnect all outgoing cable earth connections and the bonding of the feeder pillar. The earthing facility shall accommodate up to 25mm² earth conductors.
- 4.17.2.7. All control pillars shall be fitted with a durable warning sign, fitted externally and in a prominent position, indicating "DANGER 415 VOLTS" or "DANGER 240 VOLTS" as appropriate and a 'lightning flash' in black on yellow.

4.17.3. Pole mounted control pillars

- 4.17.3.1. This shall be a multi row Type A-Distribution board (distance between rows 150mm) which is fully type tested with a conditional short circuit rating of 15kA to IEC 61439.
- 4.17.3.2. The PM control pillars shall be a minimum of 540mm x 300mm x 160mm (H x W x D) suitable for mounting on wooden or concrete poles and shall have a mounting bracket suitable for pole diameters of 190mm to 230mm.
- 4.17.3.3. It shall be fitted with at least three (3) DIN rails and a main bus-bar which shall be removable for flexible installation and a fully shrouded neutral bus-bar for increased safety.
- 4.17.3.4. It shall be complete with a 'full form' blanking modules for unused MCB ways to provide a secure shrouding of unused bus-bar stabs for increased electrical

Issued by: Head of Section, Standards Development

Authorized by: Head of Department, Standards

Signed:

Signed:

Date: 2015-10-08

Date: 2015-10-08



TITLE:
SPECIFICATION FOR STREET LIGHTING ACCESSORIES

Doc. No.	KP1/6C.1/13/TSP/15/002
Issue No.	2
Revision No.	3
Date of Issue	2015-10-08
Page 43 of 79	

safety. Blanking modules shall have interlinking form for improved positional security.

- 4.17.3.5. It shall be suitable for metering and to suit application needs and aid compliance with latest Building Regulation – part L2.
- 4.17.3.6. The doors shall open 180° to provide easy access and device operation.
- 4.17.3.7. It shall be supplied complete with an incomer switch disconnecter rated 125A to provide a higher rated solution for street lighting.
- 4.17.3.8. There shall be a provision to electrically connect two distribution boards together vertically from a single supply cable to expand number of MCB ways.
- 4.17.3.9. The technical parameters shall be as per Table 15.

Table 15: Technical parameters for Control pillars

Particulars	Requirement	
	Surface mounting	Pole mounting
Type of pillar	Type A as per IEC 61439-1	
Standard of manufacture	IEC 61439-1 & 3	
Rated current (In)	200A	125 A
Rated short circuit withstand current	15 kA for 1s	
Rated frequency	50 Hz	
Rated diversity factor	0.8	
Power frequency withstand voltage, Vrms	AC	1.8 kVrms
	DC	2.67 kV
Impulse withstand voltage	2.5 kVpk	
Type of coordination overload characteristics	Specify	
Pollution degree	III	
Types of system earthing	Solidly earthed system	
Indoor and/or outdoor installation	Outdoor	
Stationary or movable	Removable	
Degree of protection	IP 54	
Intended for use by skilled or ordinary persons	Ordinary persons	
Electromagnetic compatibility (EMC) classification	Performance criterion B as per IEC 61439-1	
External design	Specify	
Mechanical impact protection	At least IK 08 as per IEC 62262	
The type of construction	Specify	Specify
The nature of short-circuit protective device(s)	Specify	Specify
Measures for protection against electric shock	Specify	Specify
Overall dimensions (including projections e.g handles, covers, doors)	Specify	Specify
The weight	Specify	Specify

Issued by: Head of Section, Standards Development

Authorized by: Head of Department, Standards

Signed:

Signed:

Date: 2015-10-08

Date: 2015-10-08



TITLE:
SPECIFICATION FOR STREET LIGHTING ACCESSORIES

Doc. No.	KP1/6C.1/13/TSP/15/002
Issue No.	2
Revision No.	3
Date of Issue	2015-10-08
Page 44 of 79	

4.18. EARTH RODS

4.18.1. Design

- 4.18.1.1. The copper-clad earth rod shall be manufactured in accordance with to BS 7430, KS 04-744 and KP1/3CB/TSP/06/031-1 standard requirements. This will include an assessment of the safety, reliability and long term performance of the items tendered.
- 4.18.1.2. The copper clad earth rod shall be manufactured from a steel rod reference symbol P of a grade with tensile strength of 550 MPa to 700 MPa in accordance with BS PD 970: 2005 standard requirements; a Brinell hardness shall be 248 to 302 HBW as recommended by BS 7430 standard.
- 4.18.1.3. An earth electrode shall be designed to have a loading capacity adequate for the system of which it forms a part, i.e. it shall be capable of dissipating the electrical energy in the earth path at the point at which it is installed under any condition of operation on the system.
- 4.18.1.4. Copper-clad steel earth rods shall be made by molecularly bonding 99.9% pure copper onto the high carbon, low tensile steel rods to achieve a minimum copper thickness of 0.254 mm (254 μm). The application of the copper sheath shall prevent any electrolytic action to be initiated by moisture ingress between the copper and the steel.

4.18.2. Sizes

4.18.3. The sizes of the earth rods shall be in accordance with KS 04-744 and Table 16.

Table16: Earth rod sizes

Nominal size		Rod length	
mm	Inches*	mm	Feet*
12.5	½ "	1,200	4'
16.0	5/8"	1,500	5'
20.0	¾ "	2,100	7'
25.0	1"	3,000	12'

* The imperial sizes have been replaced by the metric sizes in this specification for clarity.

Issued by: Head of Section, Standards Development	Authorized by: Head of Department, Standards
Signed:	Signed:
Date: 2015-10-08	Date: 2015-10-08



TITLE:
SPECIFICATION FOR STREET LIGHTING ACCESSORIES

Doc. No.	KP1/6C.1/13/TSP/15/002
Issue No.	2
Revision No.	3
Date of Issue	2015-10-08
Page 45 of 79	

4.19. QUALITY MANAGEMENT SYSTEM

4.19.1. The supplier shall submit a quality assurance plan (QAP) that will be used to ensure that the cable guard physical, tests and documentations, will fulfill the requirements stated in the contract documents, standards, specifications and regulations.

4.19.2. The Manufacturer's Declaration of Conformity to applicable standards and copies of quality management certifications shall be submitted with the tender for evaluation.



5. TESTS AND INSPECTION.

- 5.1. The street lighting accessories shall be inspected and tested in accordance with the requirements of the respective standards of manufacture and the requirements of this specification. It shall be the responsibility of the supplier to perform or to have performed all the tests specified.
- 5.2. Copies of previous **Test Reports and Test Certificates confirming compliance to clause 4 requirements for the street lighting accessories issued by a third party testing laboratory that is accredited to ISO/IEC 17025** shall be submitted with the tender for the purpose of technical evaluation. The accreditation certificate for the third party testing laboratory shall also be submitted with the tender (all in English Language).
- 5.3. Test Reports and Certificates for the street lighting accessories to be supplied under the contract shall be submitted to The Kenya Power & Lighting Company for approval before shipment/delivery.
- 5.4. The street lighting accessories shall be inspected and tested as per clause 5.1 and the specification requirements before acceptance to The Kenya Power & Lighting Company stores. The supplier shall replace any items which fail to meet any of the requirements during inspection/test at the stores or when used.
- 5.5. On receipt of the street lighting accessories, KPLC will inspect them and may perform or have performed any of the relevant tests in order to verify compliance with the specification. The supplier shall replace without charge to KPLC, street lighting accessories which upon examination, test or use fail to meet any of the requirements in the specification.

6. MARKING AND PACKING

6.1. Marking

The street lighting accessories shall be indelibly and permanently marked as per the respective manufacturing standard requirements on marking and the following:

Issued by: Head of Section, Standards Development	Authorized by: Head of Department, Standards
Signed: 	Signed: 
Date: 2015-10-08	Date: 2015-10-08



TITLE:
SPECIFICATION FOR STREET LIGHTING ACCESSORIES

Doc. No.	KP1/6C.1/13/TSP/15/002
Issue No.	2
Revision No.	3
Date of Issue	2015-10-08
Page 46 of 79	

- a) The manufacturer or supplier identity,
- b) The designation of lighting accessory,
- c) The product dimensions in millimetres;
- d) The words "**Property of KPLC**".

6.2. Packing

6.2.1. The packaging of the street lighting accessories shall vary from item to item and it shall be at the manufacturer discretion to pack the items the best way possible so as to avoid damages during transportation, handling and storage.

6.2.2. The packages shall be clearly marked with the following information;

- a) The manufacturer's and/or supplier's identification;
- b) Name of country of manufacture;
- c) Dimensions in millimeters;
- d) Quantity per box;
- e) The words "**Property of KPLC**".

NOTE: *Standard provisions for marking and packaging shall take precedence.*

7. DOCUMENTATION

7.1. The bidder shall submit its tender complete with technical documents required by Annex A (Guaranteed Technical Particulars) for tender evaluation. The technical documents to be submitted (all in English Language) for tender evaluation shall include the following:

- a) Fully filled clause by clause description of the item on offer as per Annex A (Guaranteed Technical Particulars) and signed by the manufacturer;
- b) Copies of the Manufacturer's catalogues, brochures, drawings and technical data;
- c) Sales records for the last five years and customer reference letters;
- d) Details of manufacturing capacity and the manufacturer's experience;
- e) Copies of required type test reports by a third party testing laboratory accredited to ISO/IEC 17025;
- f) Copy of accreditation certificate to ISO/IEC 17025 for the third party testing laboratory;
- g) Manufacturers letter of authorization, quality certificate and other technical documents required in the tender.

7.2. The successful bidder (supplier) shall submit the following documents/details to The Kenya Power & Lighting Company for approval before manufacture:

- a) Guaranteed Technical Particulars signed by the manufacturer;
- b) Design Drawings with details of accessories to be manufactured for KPLC.

Issued by: Head of Section, Standards Development	Authorized by: Head of Department, Standards
Signed:	Signed:
Date: 2015-10-08	Date: 2015-10-08





TITLE:
SPECIFICATION FOR STREET LIGHTING ACCESSORIES

Doc. No.	KP1/6C.1/13/TSP/15/002
Issue No.	2
Revision No.	3
Date of Issue	2015-10-08
Page 47 of 79	

- c) Quality assurance plan (QAP) that will be used to ensure that the design, material; workmanship, tests, service capability, maintenance and documentation will fulfill the requirements stated in the contract documents, standards, specifications and regulations.
- d) Detailed test program to be used during factory testing
- e) Manufacturer's undertaking to ensure adequacy of the design, good engineering practice, adherence to the specification and applicable standards and regulations as well as ensuring good workmanship in the manufacture of the accessories for The Kenya Power & Lighting Company;
- f) Packaging details and quantity per package.

7.3. The supplier shall submit recommendations for use, care, storage and routine inspection/testing procedures, all in the English Language, during delivery of the street lighting accessories to KPLC stores

Issued by: Head of Section, Standards Development	Authorized by: Head of Department, Standards
Signed: 	Signed: 
Date: 2015-10-08	Date: 2015-10-08



TITLE:
SPECIFICATION FOR STREET LIGHTING ACCESSORIES

Doc. No.	KP1/6C.1/13/TSP/15/002
Issue No.	2
Revision No.	3
Date of Issue	2015-10-08
Page 48 of 79	

ANNEX A: Guaranteed Technical Particulars (to be filled and signed by the Manufacturer and submitted together with relevant copies of the Manufacturer's catalogues, brochures, drawings, technical data, sales records for past five years, four customer reference letters, details of manufacturing capacity, the manufacturer's experience, copies of complete type test reports and accreditation certificate to ISO/IEC 17025 for the third party testing laboratory for tender evaluation, all in English Language)

Tender No.

Clause	Description	KPLC REQUIREMENTS	Bidder's offer (indicate full details of the values offered)
	Bidder's Name and address		State
1	Scope		State
4	Requirements		State
4.1	Service conditions - compliance		State
4.2	Lighting columns and Brackets		State
	Name of Manufacturer		State
	Country of manufacture		State
	Type/Model Reference Number		State
	Manufacturing standards complied with		State
	Compliance to all clauses		
4.2.1	General requirements		
	Design life	25 years	
	Dimensional limits	Post top columns (for floodlights)	12m nominal height
		Columns with brackets (HPS and LED luminaire)	8m & 10m nominal height
		Bracket projections	<Lesser of 3m or 0.25 x nominal height
	minimum thickness of structural steel sections	Plates and sections other than hollow sections	6mm
		Hollow section	4 mm
	End plates dimensions	375 x 375mm	State
	Drain hole size	10mm < size < 15mm	State
	minimum thickness backboard	15mm	State
	IP rating of doors	IP 33	State
	Keys per 10 columns	2	State
	Size of brass or stainless steel bolt	M8	State
	Width of cable entry slot	75mm	State
4.2.2	Material of manufacture		
	Material of brackets and columns	Carbon steel grade S355J2 in accordance with EN 10210	State
	Tensile strength	470 – 630 MPa	Attach test certificate
	Yield strength	355 MPa	
	Shape of steel tube	Constant diameter above the base compartment	Attach drawing
		Continuously tapered with either circular or polygonal shape	
4.2.3	Protection against corrosion		

Issued by: Head of Section, Standards Development	Authorized by: Head of Department, Standards
Signed:	Signed:
Date: 2015-10-08	Date: 2015-10-08



TITLE:
SPECIFICATION FOR STREET LIGHTING ACCESSORIES

Doc. No.	KP1/6C.1/13/TSP/15/002
Issue No.	2
Revision No.	3
Date of Issue	2015-10-08
Page 49 of 79	

Clause	Description	KPLC REQUIREMENTS			Bidder's offer (indicate full details of the values offered)
	Level of galvanization	>610 g/m ² , for flat articles >390 g/m ² , for centrifuged articles			State
	Paint colour	Grey of shade 18B25			State
	Technical particulars of the brackets as per EN 40 (relevant parts)				
	Performance under vehicle impact (impact tested at km/h)	Untested	Class 0		State
		Tested	100:NE:3		
	Partial load factor class	B		State	
	Deflection class	3		State	
	Maximum wind velocity withstand, m/s	26		State	
	Maximum luminaire weight, kg	>10m	20		State
		< 10m	10		
	Maximum luminaire windage, m ²	0.25		State	
	Minimum terrain category	II		State	
4.2.4	Marking and labeling of columns and brackets				State
4.2.5	Sizes				
	Sizes of columns	8m	10m	12m	State
	Depth of root for planting	1200mm	1500mm	1800mm	State
	Cable entry slot	65mm X 150mm			State
	Depth of top of slot below ground level	350mm			State
	Sizes of brackets	1.5m, 2.0m, 2.5m and 3.0m			State
	Diameter of curved and straight brackets	0.9-1.15m			State
	Diameter of circular brackets	1.15-2.0m			State
	Drawings and dimensions of columns complete with bracket	As per Annex B			Provide drawing
4.3	Luminaires (LED, HPS and Floodlight)				
4.3.2	LED Luminaires complete with control gear				State
	Name of Manufacturer			State	
	Country of manufacture			State	
	Type/Model Reference Number			State	
	Standard of manufacture	IEC 60598-1		State	
	Compliance to all clauses	Attach test report		State	
	Components of luminaire	Reflector, refractor and housing		State	
	Body material	LMN marine grade aluminium, or equivalent with polyester powder coating			State
	Colour	Grey, silver or black over ROHS compliant chrome passivation			State
	Finish	Polyester powder coating			State
	Components	Control gear fitted with tool-less guide release gear tray, equipped with a plug ,socket and heat barrier			State
	Mounting diameter	Side entry	State		State
		Post top entry	State		State

Issued by: Head of Section, Standards Development

Authorized by: Head of Department, Standards

Signed:

Signed:

Date: 2015-10-08

Date: 2015-10-08



TITLE:
SPECIFICATION FOR STREET LIGHTING ACCESSORIES

Doc. No.	KP1/6C.1/13/TSP/15/002
Issue No.	2
Revision No.	3
Date of Issue	2015-10-08
Page 50 of 79	

Clause	Description	KPLC REQUIREMENTS	Bidder's offer (indicate full details of the values offered)
	Integral flexible mounting system	As per clause 4.3.1.4	State
	Bowl protection	UV and vandal resistant	State
	Maximum weight	14kg	State
	Maximum windage	0.15m ²	State
	Minimum impact rating	IK08	State
	Insulation type	Double insulation	State
	Class of protection	At least class I	State
	Self-cleaning capability	Yes/No	State
	Photometric data	As per LM-78-08 (attach test report)	State
	IESNA distribution type	Type 2 or 3	State
	Light output percentage	>90%	State
	Upward light output ratio	<0.5%	State
	I _{MAX} above 95	0	State
	IP rating of lantern	IP 65	State
	Specific requirements		
	Rated input power (in W)		State
	Rated luminous flux (in lm)		State
	LED luminaire efficacy (in lm/W)		State
	Minimum operating efficiency	90%	State
	Terminals IP rating	IP2X	State
	Surge protection voltage	250 repetitive strikes of "C Low" - 6kV/1.2 x 50 μs as per IEEE/ASNI C62.41.2-2002, Scenario 1 Location Category C	State
	Short circuit current	10kA/8 x 20 μs	
	System power factor	>0.85 at full power and when dimmed.	State
	Minimum initial intensity at 100,000 hours of life / 20year minimum	95%	State
	Total lumens above 90°	Specify	State
	Photometric code	840/358	State
a	Correlated Colour Temperature (CCT in K)	=>4000K (Code 40)	State
b	Rated Colour Rendering Index (CRI)	Code 7 (CRI) range 67-76) or greater	State
c	Rated chromaticity co-ordinate values (initial and maintained)	Initial spread of chromaticity co-ordinates within a 3-step MacAdam ellipse – code 3 Maintained spread of chromaticity co-ordinates within a 5-step MacAdam ellipse – code 5	State
d	Maintained luminous flux	>80% , code 8	State
	Rated life (in h) of the LED module and the associated rated lumen maintenance (Lx) , min	70	State
	Failure fraction (Fy) corresponding to the rated life of the LED module in the luminaire, max.	10	State

Issued by: Head of Section, Standards Development

Authorized by: Head of Department, Standards

Signed:

Signed:

Date: 2015-10-08

Date: 2015-10-08



TITLE:
SPECIFICATION FOR STREET LIGHTING ACCESSORIES

Doc. No.	KP1/6C.1/13/TSP/15/002
Issue No.	2
Revision No.	3
Date of Issue	2015-10-08
Page 51 of 79	

Clause	Description	KPLC REQUIREMENTS	Bidder's offer (indicate full details of the values offered)
	Ambient temperature (ta) for a luminaire, °C	35	State
	Power Factor	>0.85	State
	Intensity Distribution	Relative Photometry as per EN13032-1	State
	Drive Current, mA, maximum	700	State
	Optical Risk, min	Risk group 2 as per IEC 62472	State
	Ageing time (h), if different to 0 h		State
	Temperature cycling, energized		State
	Minimum system performance criteria		State
	Accelerated operation life test		State
	The T _c life	65°C	State
	System life @ T _c life (min 90%)	50.000hrs	State
	The T _c min	-20°C (start up at -40°C)	State
	The T _c Max	+75°C	State
	The T _c thermal cutoff module	+75°C (starts dimming)	State
	The T _c thermal cutoff driver	+85°C (maximum dimming)	State
	Input voltage	220 – 250V	State
	Class of protection	I	State
	LED Markings (Mandatory)	Shall be per IEC/PAS 62717	State
	Dimensions, including dimensional tolerances		State
	Availability of heat sink		State
4.3.3	LED Floodlighting Luminaire complete with control gear		State
	Name of Manufacturer		State
	Country of manufacture		State
	Type/Model Reference Number		State
	Standard of manufacture	IEC 60598-1	
	Compliance to all clauses	Attach test report	State
	Components of luminaire	Reflector, refractor and housing	State
	Body material	LMN marine grade aluminium, or equivalent with polyester powder coating	State
	Colour	Grey, silver or black over ROHS compliant chrome passivation	State
	Finish	Polyester powder coating	State
	Components	Control gear fitted with tool-less guide release gear tray, equipped with a plug ,socket and heat barrier	State
	Mounting diameter	Side entry	State
		Post top entry	State
	Integral flexible mounting system	As per clause 4.3.1.4	State
	Bowl protection	UV and vandal resistant	State
	Maximum weight	14kg	State
	Maximum windage	0.1m ²	State

Issued by: Head of Section, Standards Development

Authorized by: Head of Department, Standards

Signed:

Signed:

Date: 2015-10-08

Date: 2015-10-08



TITLE:
SPECIFICATION FOR STREET LIGHTING ACCESSORIES

Doc. No.	KP1/6C.1/13/TSP/15/002
Issue No.	2
Revision No.	3
Date of Issue	2015-10-08
Page 52 of 79	

Clause	Description	KPLC REQUIREMENTS	Bidder's offer (indicate full details of the values offered)
	Minimum impact rating	IK08	State
	Insulation type	Double insulation	State
	Class of protection	At least class I	State
	Self-cleaning capability	Yes/No	State
	Photometric data	As per LM-78-08 (attach test report)	State
	IESNA distribution type	Type 2 or 3	State
	Light output percentage	>90%	State
	Upward light output ratio	<0.5%	State
	I _{MAX} above 95	0	State
	IP rating of lantern	IP 65	State
	Specific requirements		
	Rated input power (in W)	Specify	State
	Rated luminous flux (in lm)	≥400 W	40,000 lm
		350-399 W	35,000 lm
		300-349 W	30,000 lm
		250-299W	25,000 lm
	Drive Current, mA, maximum	350 - 1050	State
	LED floodlight luminaire efficacy (in lm/W), min	100 lm/W, min	State
	Salt spray test	2500 hour	State
	All external screws, bolts, washers	V4A (1.4401) or equivalent stainless-steel	State
	Mounting bracket	Stepless tilting	State
	Tilt Angle	< 15°	State
	ULR (Upward Light Ratio) value	0.0%	State
	Minimum ingress protection rate	IP65	State
	LED Lighting Units	Individual replaceable LED lighting units.	State
	Optical lens	Made of high-transparent non-yellowing PMMA.	State
	Built in Redundancy ratio:	4:1	State
	Hot Restrike (Instant On)	Yes	State
	Control	DALI (Digital Addressable Lighting Interface) or a 1-10V control interface.	State
	Surge Protection	10kV	State
	Colour Rendering Index (Ra)	70	State
	Correlated colour temperature (CCT)	>4,000	State
	Operational Life Expectancy	50,000 hours (L70).	State
	The lumen output drop	> 70% of the initial output	State
	Compliance	CIBSE, ISO 9001 and ISO 14001 certified.	State
	LED Markings (Mandatory)	Shall be per IEC/PAS 62717	State
	Certifications	CE certified and all components shall be ENEC and UL certified	State

Issued by: Head of Section, Standards Development

Authorized by: Head of Department, Standards

Signed:

Signed:

Date: 2015-10-08

Date: 2015-10-08



TITLE:
SPECIFICATION FOR STREET LIGHTING ACCESSORIES

Doc. No.	KP1/6C.1/13/TSP/15/002
Issue No.	2
Revision No.	3
Date of Issue	2015-10-08
Page 53 of 79	

Clause	Description	KPLC REQUIREMENTS	Bidder's offer (indicate full details of the values offered)
		Photobiological certificate in compliance with IEC 62471 validating the safety of the LEDs and shall not be classified higher than "Exempt Risks"	State
		RoHS compliant.	State
4.3.4	High Pressure Sodium (HPS) Luminaire complete with control gear		
	Name of Manufacturer		State
	Country of manufacture		State
	Type/Model Reference Number		State
	Standard of manufacture	IEC 60598-1	State
	Compliance to all clauses	Attach test report	State
	Components of luminaire	Reflector, refractor and housing	State
	Body material	LMN marine grade aluminium, or equivalent with polyester powder coating	State
	Colour	Grey, silver or black over ROHS compliant chrome passivation	State
	Finish	Polyester powder coating	State
	Components	Control gear fitted with tool-less guide release gear tray, equipped with a plug ,socket and heat barrier	State
	Mounting diameter	Side entry 42mm to 60mm	State
		Post top entry State	
	Integral flexible mounting system	As per clause 4.3.1.4	State
	Bowl protection	UV and vandal resistant	State
	Maximum weight	10kg	State
	Maximum windage	0.15m ²	State
	Minimum impact rating	IK 08 as per IEC 62262	State
	Insulation type	Double insulation	State
	Class of protection	Class I	State
	Self-cleaning capability	Yes/No	State
	Photometric data	As per LM-78-08 (attach test report)	State
	IESNA distribution type	Type 2 or 3	State
	Light output percentage	>90%	State
	Upward light output ratio	<0.5%	State
	I _{MAX} above 95%	0	State
	IP rating of lantern	IP 65	State
	Minimum Performance Criteria		
	Ratings in W	150 250 400	150 250 400
	Rated Luminous Efficacy lm/W (100hrs), min	110 110 110	Fill
	Luminance, Lm, min	16,500 27,500 44,000	Fill
	LSF @ 16,000hrs	0.96 0.96 0.96	Fill
	LLMF @ 16,000hrs	0.94 0.94 0.94	Fill
	Correlated Color Temp.Tc (K)	2000 2000 2000	Fill
	Max. Color Rendering (Ra)	25 25 25	Fill
4.3.5	High Pressure Sodium (HPS) Flood lights Luminaire with integral ballast.		
	Name of Manufacturer		State

Issued by: Head of Section, Standards Development

Authorized by: Head of Department, Standards

Signed:

Signed:

Date: 2015-10-08

Date: 2015-10-08



TITLE:
SPECIFICATION FOR STREET LIGHTING ACCESSORIES

Doc. No.	KP1/6C.1/13/TSP/15/002
Issue No.	2
Revision No.	3
Date of Issue	2015-10-08
Page 54 of 79	

Clause	Description	KPLC REQUIREMENTS	Bidder's offer (indicate full details of the values offered)	
	Country of manufacture		State	
	Type/Model Reference Number		State	
	Standard of manufacture	IEC 60598-1	State	
	Compliance to all clauses	Attach test report	State	
	Components of luminaire	Reflector, refractor and housing	State	
	Body material	LMN marine grade aluminium, or equivalent with polyester powder coating	State	
	Colour	Grey, silver or black over ROHS compliant chrome passivation	State	
	Finish	Polyester powder coating	State	
	Components	Control gear fitted with tool-less guide release gear tray, equipped with a plug ,socket and heat barrier	State	
	Mounting diameter	Side entry	42mm to 60mm	State
		Post top entry	60mm to 76mm	State
	Integral flexible mounting system	As per clause 4.3.1.4	State	
	Bowl protection	UV and vandal resistant	State	
	Maximum weight	10kg	State	
	Maximum windage	0.15m ²	State	
	Minimum impact rating	IK08 as per IEC 62262	State	
	Insulation type	Double insulation	State	
	Class of protection	Class I	State	
	Self-cleaning capability	Yes/No	State	
	Photometric data	As per LM-78-08 (attach test report)	State	
	IESNA distribution type	Type 2 or 3	State	
	Light output percentage	>90%	State	
	Upward light output ratio	<0.5%	State	
	I _{MAX} above 95	0	State	
	IP rating of lantern	IP 65 as per IEC 60529	State	
	Specific requirements			
	Design	Compact rugged design	State	
	Power ratings	250W / 400W	State	
	Fixing design	6.35mm captive stainless steel slotted hex-head bolts	State	
	Socket and lamp contact material	h/duty mogul-base porcelain, heavy gauge brass, nickel plated double lamp-grip screw and spring loaded centre contact	State	
	Reflector design	Compound parabolic, double segmented finished aluminum	State	
	Mounting design	Built-in slip fitter, adjustable laterally with steel mounting	State	
	Inner housing	HP aluminium die-cast with high purity anodized hammered finish	State	
	Glass design	Frameless thermal resistant tempered glass	State	
4.4	High Pressure Sodium (HPS) Lamps			
	Name of Manufacturer		State	

Issued by: Head of Section, Standards Development

Authorized by: Head of Department, Standards

Signed:

Signed:

Date: 2015-10-08

Date: 2015-10-08



TITLE:
SPECIFICATION FOR STREET LIGHTING ACCESSORIES

Doc. No.	KP1/6C.1/13/TSP/15/002
Issue No.	2
Revision No.	3
Date of Issue	2015-10-08
Page 55 of 79	

Clause	Description	KPLC REQUIREMENTS			Bidder's offer (indicate full details of the values offered)
	Country of manufacture				State
	Type/Model Reference Number				State
	Standard of manufacture	IEC 60598-1			State
	Compliance to all clauses	Attach test report			State
	Nominal wattage, W	150	250	400	State
	Circuit	With external ignitor			State
	Starting and warm-up characteristics - Starting				
	Test voltage (r.m.s.), Vmax	198	198	198	State
	Starting time, s	5	5	5	State
	Pulse characteristics				
	Height (peak) A, V	2475-2,500	3,300	3,300	State
	Width T ₂ at 50 % of A, µs	1.0	2.0	2.0	State
	Repetition rate	1/half cycle	1/full cycle	1/full cycle	State
	Phase angle, °	60-90	90	90	State
	Starting and warm-up characteristics - Warm-up				
	Test voltage, V	198	198	198	State
	Time required to reach 45 V minimum at lamp terminals, min	5	7	7	State
	Electrical characteristics				
	Wattage, W	148	245	380	State
	Voltage (r.m.s.) at lamp terminals, V	90	85-115	85-115	State
	Current (r.m.s.), A	2.0	2.95	4.5	State
	Extinguishing voltage r.m.s., V	111	120	125	State
	Photometric characteristics				
	Correlated colour temperature (nominal), K	-	2,170	2,170	State
	Chromaticity co-ordinates x/y (nominal)	-	0.510/0.420	0.510/0.420	State
	Colour rendering index Ra (nominal)	-	≥60	≥60	State
4.5.	Photo Electric Cell Units (PECUs)				
	Type I – Ordinary PECU				
	Name of Manufacturer				State
	Country of manufacture				State
	Type/Model Reference Number				State
	Manufacturing standards complied with				State
	Compliance to all clauses				State
	Guaranteed for a minimum life	6 years			State
	Protection against electric shock	Class 2			State
	IP rating	IP65 as per IEC 60529			State
	Operating voltage, frequency	220-250V, 50Hz			State
	Current rating	16 A			State
	Contacts	Single-pole/single-throw; normally closed at night			State
	Contact load rating	1000 Watts incandescent; 1800 VA H.I.D			State
	Surge Protection	Expulsion or Metal-Oxide-Varistor type arrestor			State

Issued by: Head of Section, Standards Development

Authorized by: Head of Department, Standards

Signed:

Signed:

Date: 2015-10-08

Date: 2015-10-08



TITLE:
SPECIFICATION FOR STREET LIGHTING ACCESSORIES

Doc. No.	KP1/6C.1/13/TSP/15/002'
Issue No.	2
Revision No.	3
Date of Issue	2015-10-08
Page 56 of 79	

Clause	Description	KPLC REQUIREMENTS	Bidder's offer (indicate full details of the values offered)
	Turn-on level	1.0-1.5 lumens	State
	Turn-on to Turn-off ratio	1:2- 1:5	State
	Temperature range	-20°C to +80°C.	State
	Pre-set switch on/off level	35/18 lux	State
	Negative switching differential	1:0.5.	State
	Power consumption	<0.5W	State
	Type II -PECU complete with Timer Switch		
	Name of Manufacturer		State
	Country of manufacture		State
	Type/Model Reference Number		State
	Manufacturing standards complied with		State
	Compliance to all clauses by attaching catalogue		Attach catalogue
	Guaranteed for a minimum life	6 years	State
	Protection against electric shock	Class 2	State
	IP rating	IP65 as per IEC 60529	State
	Operating voltage, frequency	220-250V, 50Hz	State
	Current rating	16 A	State
	Contacts	Single-pole/single-throw; normally closed at night	State
	Contact load rating	3000 Watts incandescent; 1800 VA H.I.D	State
	Surge Protection	Expulsion or Metal-Oxide-Varistor type arrester	State
	Type III – GSM enabled PECU complete with Timer Switch		
	Name of Manufacturer		State
	Country of manufacture		State
	Type/Model Reference Number		State
	Manufacturing standards complied with		State
	Compliance to all clauses		State
	Features – prove compliance for all the features by attaching a catalogue		Attach catalogue
	Guaranteed for a minimum life	6 years	State
	Protection against electric shock	Class 2	State
	IP rating	IP65 as per IEC 60529	State
	Operating voltage, frequency	220-250V, 50Hz	State
	Current rating	16 A	State
	Contacts	Single-pole/single-throw; normally closed at night	State
	Contact load rating	3000 Watts incandescent; 1800 VA H.I.D	State
	Surge Protection	Expulsion or Metal-Oxide-Varistor type arrester	State
4.6	Timers for Street Lighting		
	Name of Manufacturer		State
	Country of manufacture		State
	Type/Model Reference Number		State
	Manufacturing standards complied with		State
	Compliance to clauses design clauses		
	Rated voltage and frequency	230V AC, 50 Hz	State
	Load carrying capacity	6-12 kW	State
	IP rating	IP 40 as per IEC 60529	State
	Operating Voltage	220 - 240 Vac	State
	Program Functions	ON / OFF	State
	Number of Memory Locations	48	State

Issued by: Head of Section, Standards Development

Authorized by: Head of Department, Standards

Signed:

Signed:

Date: 2015-10-08

Date: 2015-10-08



TITLE:
SPECIFICATION FOR STREET LIGHTING ACCESSORIES

Doc. No.	KP1/6C.1/13/TSP/15/002
Issue No.	2
Revision No.	3
Date of Issue	2015-10-08
Page 57 of 79	

Clause	Description	KPLC REQUIREMENTS			Bidder's offer (indicate full details of the values offered)			
	Power Reserve	150 Hrs			State			
	Max. Switching Capacity at 250 VAC cosΦ = 1	16 A			State			
	Max. Switching Capacity at 250 VAC cosΦ = 0.6	10 A			State			
	HPS Lamps	2300 watt			State			
	Shortest Switching Time	15 Min			State			
4.7.	High intensity discharge ballasts							
	Name of Manufacturer						State	
	Country of manufacture						State	
	Model/Reference Number						State	
	Manufacturing standards complied with						State	
	Ballast type	Vacuum pressure impregnated			State			
	Insulation rating	Class H			State			
	Efficiency	88%			State			
	Characteristic curve	As per IEC 60662			State			
	Voltage tolerance	+2.5%			State			
	Characteristics of ballasts							
	Wattage (W)	150	250	400	150	250	400	
	Connection type	CWA	CWA	CWA				
	Nominal lamp wattage	150	250	400				
	Frequency, Hz	50	50	50				
	Rated voltage, V	200	220	220				
	Calibration current, A	2.0	3.0	4.6				
	Voltage/current ratio	81.0 ± 0.5%	60.0	39				
	Power factor(λ)	0.060±0.010	0.06±0.005	0.06±0.00				
				5				
	Pulse width	2.0-3.6	3.0-5.2	4.6-7.5				
	Lamp warm-up current (r.m.s.), A	2,700-4,500	<5,000	<5,000				
	Pulse height (peak), luminaire requirement, V	10	10	12				
	Temperature rise	180	180	180				
4.8	Capacitors for Luminaires							
	Name of Manufacturer						State	
	Country of manufacture						State	
	Type/Model/Reference Number						State	
	Manufacturing standards complied with						State	
	Connection type	Primary side of transformer ballast			State			
	Type	Resin encapsulated			State			
	Power factor(λ)	0.88 lagging			State			
	Characteristics of capacitors for Luminaires							
	Lamp	Wattage	150	250	400	150	250	400
		Current	1.8	3.0	4.4			
	Capacitor	µF± 5%	21	33	46			
4.9	Ignitors for luminaires							
	Name of Manufacturer						State	
	Country of manufacture						State	
	Type/Model Reference Number						State	

Issued by: Head of Section, Standards Development

Authorized by: Head of Department, Standards

Signed:

Signed:

Date: 2015-10-08

Date: 2015-10-08



TITLE:
SPECIFICATION FOR STREET LIGHTING ACCESSORIES

Doc. No.	KP1/6C.1/13/TSP/15/002
Issue No.	2
Revision No.	3
Date of Issue	2015-10-08
Page 58 of 79	

Clause	Description	KPLC REQUIREMENTS	Bidder's offer (indicate full details of the values offered)
	Manufacturing standards complied with		State
	Compliance to all clauses		State
	Operating temperature	90°C	State
	Igniters electrical characteristics		
	Lamp wattage , W	150, 250, 400	150 250 400
	Switch on voltage , V	≤ 200	State
	Switching off voltage, V	> 168	State
	Voltage peak, kV	3.4	State
	Load capacitance, pF	155	State
	Losses at peak current of 4.5A , W	2.7	State
	Pulse width	2.0-3.6 3.0-5.2 4.6-7.5	
	Lamp warm-up current (r.m.s.), A	2,700-4,500 <5,000 <5,000	
	Pulse height (peak), luminaire requirement, V	10 10 12	
4.10	Miniature Circuit Breakers (MCB)		
	Name of Manufacturer		State
	Country of manufacture		State
	Type/Model Reference Number		State
	Manufacturing standards complied with		State
	Compliance to all clauses		State
	Number of poles	Two (2) Pole Single Throw snap-action	
	Protection against external influences	Enclosed type	
	Method of mounting	Panel board type	
	Method of connection	Screw-in type	
	Value of rated operational voltage	220 – 250V AC	
	Value of rated current	10A, 16A, 25A, 32A, 40A and 63A	
	Value of rated frequency	50 Hz	
	Range of instantaneous tripping current	Above 5In upto and including 10In	
	Value of rated short-circuit capacity	10 kA	
	I ² t characteristic	Attach the characteristic curve	
	I ² t classification		
	Endurance	Exceeds 10,000 trippings at 200% rated load	
	Insulation Resistance	100 MΩ	
	Ambient temperature	0...+50 °C	
4.11	Consumer unit		
	Name of Manufacturer		State
	Country of manufacture		State
	Type/Model Reference Number		State
	Manufacturing standards complied with		State
	Compliance to all clauses		State
	Standard of manufacture	IEC 61439-1 & 3	State
	Max. load/ No of ways	100A, 6-Way SPN	State
	Maximum voltage	220-250 V AC , 50Hz	State
	Degree of protection	IP 46	State
	Enclosure material	Aluzinc steel sheet or galvanized steel	State
	Steel thickness – Box and cover	1 mm	State

Issued by: Head of Section, Standards Development

Authorized by: Head of Department, Standards

Signed:

Signed:

Date: 2015-10-08

Date: 2015-10-08



TITLE:
SPECIFICATION FOR STREET LIGHTING ACCESSORIES

Doc. No.	KP1/6C.1/13/TSP/15/002
Issue No.	2
Revision No.	3
Date of Issue	2015-10-08
Page 59 of 79	

Clause	Description	KPLC REQUIREMENTS	Bidder's offer (indicate full details of the values offered)
	Knock-outs - body	Top, bottom and rear	State
	Enclosure finish	Gray, RAL 7035 Polyester epoxy powder paint	State
	Paint thickness	60-80 microns	State
	Incomer	Switch isolator, 100A	State
		RCCBO (see clause 4.11) , Frame size 100A : 50mm ²	State
	Neutral terminal bar	16mm ²	State
	Earth terminal bar	16mm ²	State
	Minimum clearances in air	Phase to phase – 25.4mm	State
		Phase to earth – 25.4mm	State
	Minimum creepage distances	Phase to phase -50.8mm	State
		Phase to earth -25.4mm	State
	EMC requirements	Performance requirements criteria for environment class B as per Table J.1 of IEC 61439	State
	Rated power frequency withstand	AC - 2 kVrms / 5s	State
		DC – 2.83 kV	State
	Rated impulse voltage	2.5 kV peak	State
	Short circuit withstand capacity	10kA/1s	State
	Approximate dimension (H x W x D) mm	256 x 368 x 110 mm	
4.12.	Earth leakage circuit breaker		
	Name of Manufacturer		State
	Country of manufacture		State
	Type/Model Reference Number		State
	Manufacturing standards complied with		State
	Compliance to all clauses		State
	Technical characteristics of ELCB		
	Number of Poles	1P+N	State
	Rated Current(A)	40	State
	Rated Residual Operating Current(I _n)(mA)	30	State
	Rated Residual Non-operation Current(I _{no})(mA)	0.5I _n	State
	Rated Voltage(V), frequency	230/400, 50Hz	State
	Residual Current Off-time	0.1S	State
	Short Circuit Capacity(I _{cu})	3000A	State
	Endurance	4000	State
	Tripping Curve	C,D	State
	Degree of protection	IP20	State
	Operating time	30ms	State
4.13	Lighting contactors		
	Name of Manufacturer		State
	Country of manufacture		State
	Type/Model Reference Number		State
	Manufacturing standards complied with		State
	Compliance to all clauses		State

Issued by: Head of Section, Standards Development

Authorized by: Head of Department, Standards

Signed:

Signed:

Date: 2015-10-08

Date: 2015-10-08



TITLE:
SPECIFICATION FOR STREET LIGHTING ACCESSORIES

Doc. No.	KP1/6C.1/13/TSP/15/002
Issue No.	2
Revision No.	3
Date of Issue	2015-10-08
Page 60 of 79	

Clause	Description	KPLC REQUIREMENTS	Bidder's offer (indicate full details of the values offered)
	Technical parameters for lighting contactors		
	Type	AC operated double pole	State
	Rated operational voltage Umax	690V	State
	Rated insulation voltage	1000V	State
	Rated operational current	40A	State
	Impulse withstand voltage	8KV	State
	Maximum breaking capacity	250A	State
	Maximum electrical switching frequency for AC-1	600 cycles/h	State
	Heat dissipation per pole	1.8W	State
	Mechanical durability	3 million operating cycles	State
	Degree of enclosure	IP 20	State
4.14	Clear Cut Outs and Isolators		
	Name of Manufacturer		State
	Country of manufacture		State
	Type/Model Reference Number		State
	Manufacturing standards complied with		State
	Compliance to all clauses		State
	Current rating	40A and 63A amps	State
	Minimum degree of protection	IP 22	State
4.15	Fuses		
	Name of Manufacturer		State
	Country of manufacture		State
	Type/Model Reference Number		State
	Manufacturing standards complied with		State
	Compliance to all clauses		State
	Operating voltage, frequency	240 V, 50 Hz	State
	Current ratings	6A, for lamps up to and including 100W 10A, for lamps greater than 100W	State
4.16	Cables		
	1.5 mm² twin with earth		
	Name of Manufacturer		State
	Country of manufacture		State
	Type/Model Reference Number		State
	Manufacturing standards complied with		State
	Number & nominal area of conductor	2 x 1.5 with earth	State
	Number size of wires , No/mm	Phase - 1/1.38 , earth 1/1/0	State
	Thickness of insulation, mm	0.7	State
	Thickness of sheath , mm	0.9	State
	Nominal wire diameter, mm	4.3 x 8.3 – 5.4 x 10.0	State
	Maximum insulation resistance, at 70°C Ω/km	0.11	State
	Max. d.c resistance of the wire at 20°C, Ω/km	13.3	State
	Insulator material	TI 2	State
	Bedding material	TI 2	State
	Oversheath material	TM 1	State
	Conductor class as per IEC 60228	Class 5	State

Issued by: Head of Section, Standards Development

Authorized by: Head of Department, Standards

Signed:

Signed:

Date: 2015-10-08

Date: 2015-10-08



TITLE:
SPECIFICATION FOR STREET LIGHTING ACCESSORIES

Doc. No.	KP1/6C.1/13/TSP/15/002
Issue No.	2
Revision No.	3
Date of Issue	2015-10-08
Page 61 of 79	

Clause	Description	KPLC REQUIREMENTS	Bidder's offer (indicate full details of the values offered)
	2.5 mm² twin with earth		
	Name of Manufacturer		State
	Country of manufacture		State
	Type/Model Reference Number		State
	Manufacturing standards complied with		State
	Number & nominal area of conductor	2 x 2.5 with earth	State
	Number size of wires , No/mm	Phase - 7/0.67 , earth 7/0.46	State
	Thickness of insulation, mm	0.8	State
	Thickness of sheath , mm	1.0	State
	Nominal wire diameter, mm	5.2 x 9.8 – 6.6 x 12.5	State
	Maximum insulation resistance, at 70°C Ω/km	0.010	State
	Insulator material	TI 2	State
	Bedding material	TI 2	State
	Over-sheath material	TM 1	State
	Max. d.c resistance of the wire at 20°C, Ω/km	7.98	State
	Conductor class as per IEC 60228	Class 5	State
	6.0 mm² Cu PVC SWA cable		
	Name of Manufacturer		State
	Country of manufacture		State
	Type/Model Reference Number		State
	Manufacturing standards complied with		State
	Conductor nominal sectional area	mm ² 6	State
	Number of cores	No. 2	State
	Voltage Designation Uo/U (Um)	600/1000 (1200) V	
	Conductor shape	Stranded shaped compacted	
	Nominal insulation thickness	mm 0.8	State
	Bedding thickness	mm 0.8	State
	Average outer sheath thickness	mm 1.5	State
	Armour wire diameter	mm 0.9	State
	Maximum Armour wire resistance at 20°C	Ω/Km 7.0	State
	Minimum number of wires in the conductor	No 7	State
	Diameter of wire	mm 1.04	State
	Approx. overall diameter of cable	mm 16.5	State
	Maximum conductor resistance at 20°C	Ω/Km 3.08	State
	Minimum insulation resistance of cable for 1000m at 20°C	Ω/Km 7	State
	Approximate weight of cable	Kg/Km 541	State
	Insulating material	PVC/A	State
	Bedding material	Extruded layers of polymeric material compatible with the underlying insulation	State
	Over sheath material	ST 1	State
	Conductor class as per IEC 60228	Class 2	State
	10.0 mm² Al PVC SWA cable		
	Name of Manufacturer		State
	Country of manufacture		State
	Type/Model Reference Number		State

Issued by: Head of Section, Standards Development

Authorized by: Head of Department, Standards

Signed:

Signed:

Date: 2015-10-08

Date: 2015-10-08



TITLE:
SPECIFICATION FOR STREET LIGHTING ACCESSORIES

Doc. No.	KP1/6C.1/13/TSP/15/002
Issue No.	2
Revision No.	3
Date of Issue	2015-10-08
Page 62 of 79	

Clause	Description	KPLC REQUIREMENTS		Bidder's offer (indicate full details of the values offered)
	Manufacturing standards complied with			State
	Conductor nominal sectional area	mm ²	10	State
	Number of cores	No.	2	State
	Voltage Designation Uo/U (Um)	600/1000 (1200) V		
	Conductor shape	Stranded shaped compacted		
	Nominal insulation thickness	mm	1.0	State
	Bedding thickness	mm	0.8	State
	Average outer sheath thickness	mm	1.6	State
	Armour wire diameter	mm	1.25	State
	Maximum Armour wire resistance at 20°C	Ω/Km	6.0	State
	Minimum number of wires in the conductor	No	7	State
	Diameter of wire	mm	1.35	State
	Approx. overall diameter of cable	mm	20.1	State
	Maximum conductor resistance at 20°C	Ω/Km	3.08	State
	Minimum insulation resistance of cable for 1000m at 20°C	Ω/Km	7	State
	Approximate weight of cable	Kg/Km	235	State
	Insulating material	PVC/A		State
	Bedding material	Extruded layers of polymeric material compatible with the underlying insulation		State
	Over sheath material	ST 1		State
	Conductor class as per IEC 60228	Class 2		State
4.17	Control Pillars			
4.17.1	Ground mounted control pillars			
	Name of Manufacturer			State
	Country of manufacture			State
	Type/Model Reference Number			State
	Manufacturing standards			State
	Minimum thickness of galvanized mild steel	3mm		State
	Minimum galvanization thickness	85µm		State
	Number of ways	12-way		State
	Maximum temperature	40°C		State
	Degree of protection	IP 65 , min on the doors		State
		IP 45, min on the vent louvers		State
		IK 08, min		State
	Thickness of marine plywood or equivalent backboard	15mm		State
	Door design	Double door with tamper proof "O" locks		State
	Protection	Vermin proof screens		State
	Minimum size (H x W x D)	1,350mm x 1,200mm x 450mm		State
	Raise and backboard dimensions	400mm, 1170 x 980mm respectively		
	Application	Shall accommodate all items specified in clause 4.15.2.2 (a to j)		State

Issued by: Head of Section, Standards Development

Authorized by: Head of Department, Standards

Signed:

Signed:

Date: 2015-10-08

Date: 2015-10-08



TITLE:
SPECIFICATION FOR STREET LIGHTING ACCESSORIES

Doc. No.	KP1/6C.1/13/TSP/15/002
Issue No.	2
Revision No.	3
Date of Issue	2015-10-08
Page 63 of 79	

Clause	Description	KPLC REQUIREMENTS	Bidder's offer (indicate full details of the values offered)
	Provision for earthing	Y/N	State
	Labeling including circuit diagram in accordance to clause 4.15.2.4	Y/N	State
	A durable warning signs	Y/N	State
	Type of pillar	Type A as per IEC 61439-1	State
	Standard of manufacture	IEC 61439-1 & 3	State
	Rated current (In)	200A	State
	Rated short circuit withstand current	10 kA for 1s	State
	Rated frequency	50 Hz	State
	Rated diversity factor	0.8	State
	Power frequency withstand voltage, Vrms	A.C	1.8 kVrms
		D.C	2.67 kV
	Impulse withstand voltage	2.5 kVpk	State
	Type of coordination overload characteristics		State
	Pollution degree	III	State
	Types of system earthing	Solidly earthed system	State
	Indoor and/or outdoor installation	Outdoor	State
	Stationary or movable	Removable	State
	Degree of protection	IP 54	State
	Intended for use by skilled or ordinary persons	Ordinary persons	State
	Electromagnetic compatibility (EMC) classification	Performance criterion B as per IEC 61439-1	State
	External design	Specify	State
	Mechanical impact protection	At least IK 08 as per IEC 62262	State
	The type of construction	Specify	State
	The nature of short-circuit protective device(s)	Specify	State
	Measures for protection against electric shock	Specify	State
	Overall dimensions (including projections e.g handles, covers, doors)	Specify	State
	The weight	<	State
4.17.	Pole mounted control pillars		
2	Name of Manufacturer		State
	Country of manufacture		State
	Type/Model Reference Number		State
	Type of distribution board	multi row Type A	State
	Manufacturing standards	IEC 61439-1 & 3	State
	Minimum thickness of galvanized mild steel	3mm	State
	Minimum galvanization thickness	85µm	State
	Number of ways	12-way,	State
	Control pillar rating	200A	State
	Maximum temperature	40°C	State
	Degree of protection	IP 65, min on the doors	State
		IP 45, min on the vent louvers	State
		IK 08, min as per IEC 62262	State
	Door design	Double door with tamper proof "O" locks	State
	Minimum size (H x W x D)	540mm x 300mm x 160mm	State

Issued by: Head of Section, Standards Development

Authorized by: Head of Department, Standards

Signed:

Signed:

Date: 2015-10-08

Date: 2015-10-08



TITLE:
SPECIFICATION FOR STREET LIGHTING ACCESSORIES

Doc. No.	KP1/6C.1/13/TSP/15/002
Issue No.	2
Revision No.	3
Date of Issue	2015-10-08
Page 64 of 79	

Clause	Description	KPLC REQUIREMENTS	Bidder's offer (indicate full details of the values offered)				
	DIN rails	At least three in number	State				
	Complete with blanking plates	Y/N	State				
	Removable main bus-bar	Y/N	State				
	Suitable for protection and metering	Y/N	State				
	Doors open at 180°	Y/N	State				
	Supplied complete with a disconnecter rated 125A	Y/N	State				
	Provision to electrically connect two DBs together	Y/N	State				
	Standard of manufacture	IEC 61439-1 & 3	State				
	Rated current (In)	125A	State				
	Rated short circuit withstand current	10 kA for 1s	State				
	Rated frequency	50 Hz	State				
	Rated diversity factor	0.8	State				
	Power frequency withstand voltage, kVrms	A 1.8 kVrms	State				
		D 2.67 kV D.C	State				
	Impulse withstand voltage	2.5 kVpk	State				
	Type of coordination overload characteristics	Specify	State				
	Pollution degree	III	State				
	Types of system earthing	Solidly earthed system	State				
	Indoor and/or outdoor installation	Outdoor	State				
	Stationary or movable	Removable	State				
	Intended for use by skilled or ordinary persons	Ordinary persons	State				
	Electromagnetic compatibility (EMC) classification	Performance criterion B as per IEC 61439-1	State				
	External design	Specify	State				
	The type of construction	Specify	State				
	The nature of short-circuit protective device(s)	Specify	State				
	Measures for protection against electric shock	Specify	State				
	Overall dimensions (including projections e.g handles, covers, doors)	Specify	State				
	The weight	Specify	State				
4.18	Copper clad earth rods						
	Name of Manufacturer		State				
	Country of manufacture		State				
	Type/Model Reference Number		State				
	Manufacturing standards complied with		State				
	Compliance to all clauses		State				
	Tensile strength	550MPa to 700 MPa	State				
	Brinell hardness	248 to 302 HBW	State				
	minimum copper thickness	0.254 mm (254 µm)	State				
	Sizes		State				
	Nominal size	mm	12.5	16.0	20.0	25.0	State
		Inches *	½ "	5/8"	¾ "	1"	
	Rod length	mm	1200	1500	2100	3000	State
		Feet*	4'	5'	7'	12'	

Issued by: Head of Section, Standards Development

Authorized by: Head of Department, Standards

Signed:

Signed:

Date: 2015-10-08

Date: 2015-10-08



TITLE:
SPECIFICATION FOR STREET LIGHTING ACCESSORIES



Doc. No.	KP1/6C.1/13/TSP/15/002
Issue No.	2
Revision No.	3
Date of Issue	2015-10-08
Page 65 of 79	

Clause	Description	KPLC REQUIREMENTS	Bidder's offer (indicate full details of the values offered)
4.19	Quality Management System		
	Quality Assurance Plan		Provide
	Copy of ISO 9001:2008 Certificate		Provide
5.1	Test standards and responsibility of carrying out tests		Provide
5.2	Copies of Type Test Reports submitted with tender		Provide
5.3	Acceptance tests to be witnessed by KPLC at factory before shipment		Provide
5.4	Test reports to be submitted by supplier to KPLC for approval before shipment		Provide
5.5	Replacement of rejected insulators		State
6.1	Marking		State
6.2	Packing		State
7.1	Documents submitted with tender		State
7.2	Documents to be submitted by supplier to KPLC for approval before manufacture		State
7.3.	Recommendations for use, care, storage and routine inspection/testing procedures		Provide
8.0	Manufacturer's Guarantee and Warranty		Provide
9.0	List catalogues, brochures, technical data and drawings submitted to support the offer		Provide
10.0	List customer sales records and reference letters submitted to support the offer.		Provide
11.0	List Test Certificates submitted with tender		Provide
12.0	Manufacturer's experience and Manufacturing Capacity (units per month)		Provide
13.0	Statement of compliance to specification (indicate deviations if any & supporting documents)		Provide

.....
Manufacturer's Name, Signature, Stamp and Date

NOTE:

- 1) Bidders shall give full details and the offered values of the items on order as per Annex A. The details provided shall conform to the test reports and their certificates as required by clause 5.2., well labeled drawings complete with dimensions, catalogues or brochures for the purpose of tender evaluation.
- 2) Bidder who shall have not complied by this requirement in bullet 1 shall be automatically disqualified from bidding this item.

Issued by: Head of Section, Standards Development	Authorized by: Head of Department, Standards
Signed: 	Signed: 
Date: 2015-10-08	Date: 2015-10-08

ANNEX B: Drawings and dimensions of columns and brackets

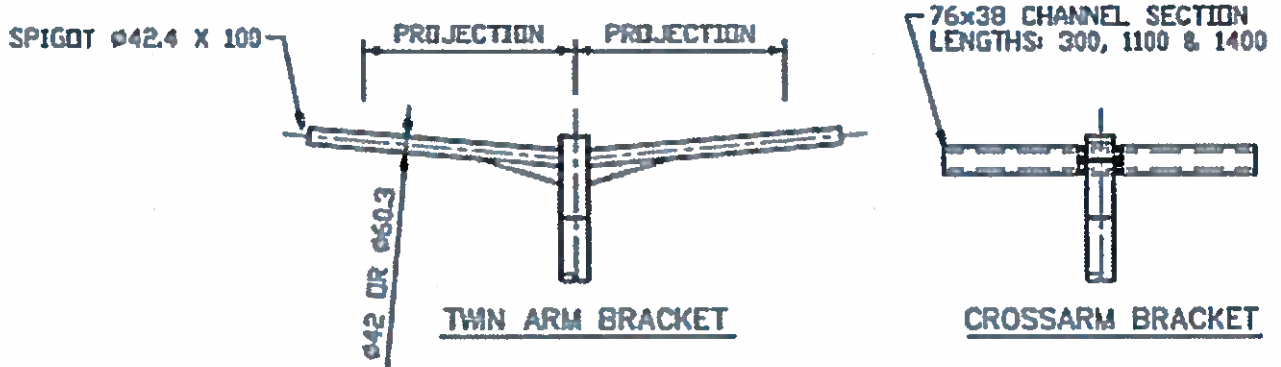

Fig. 1a. Twin and Crossarm Bracket Details for 15m column

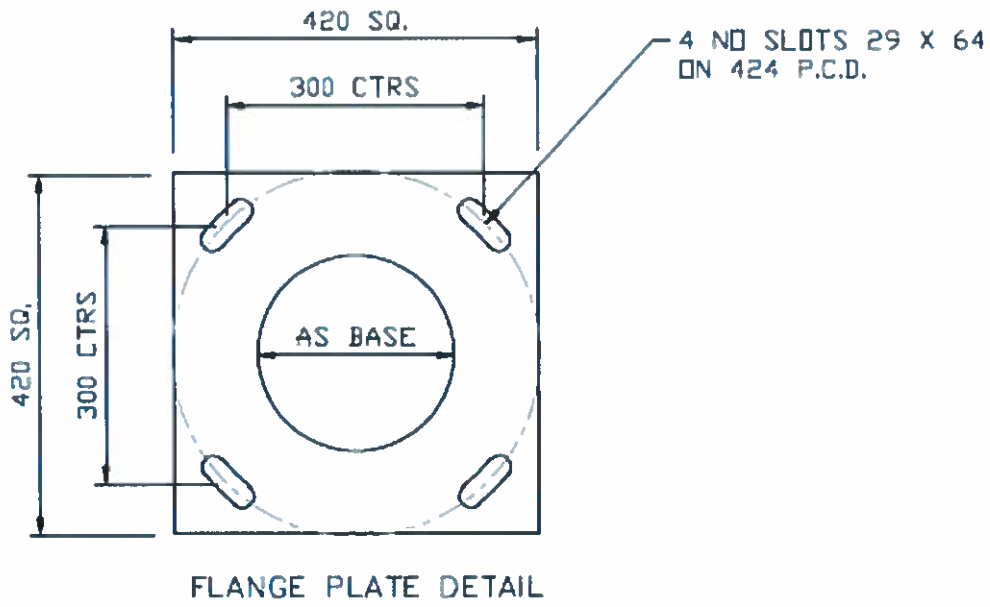

Fig. 1b. Flange Plate Detail for 15m column

Issued by: Head of Section, Standards Development	Authorized by: Head of Department, Standards
Signed: 	Signed: 
Date: 2015-10-08	Date: 2015-10-08

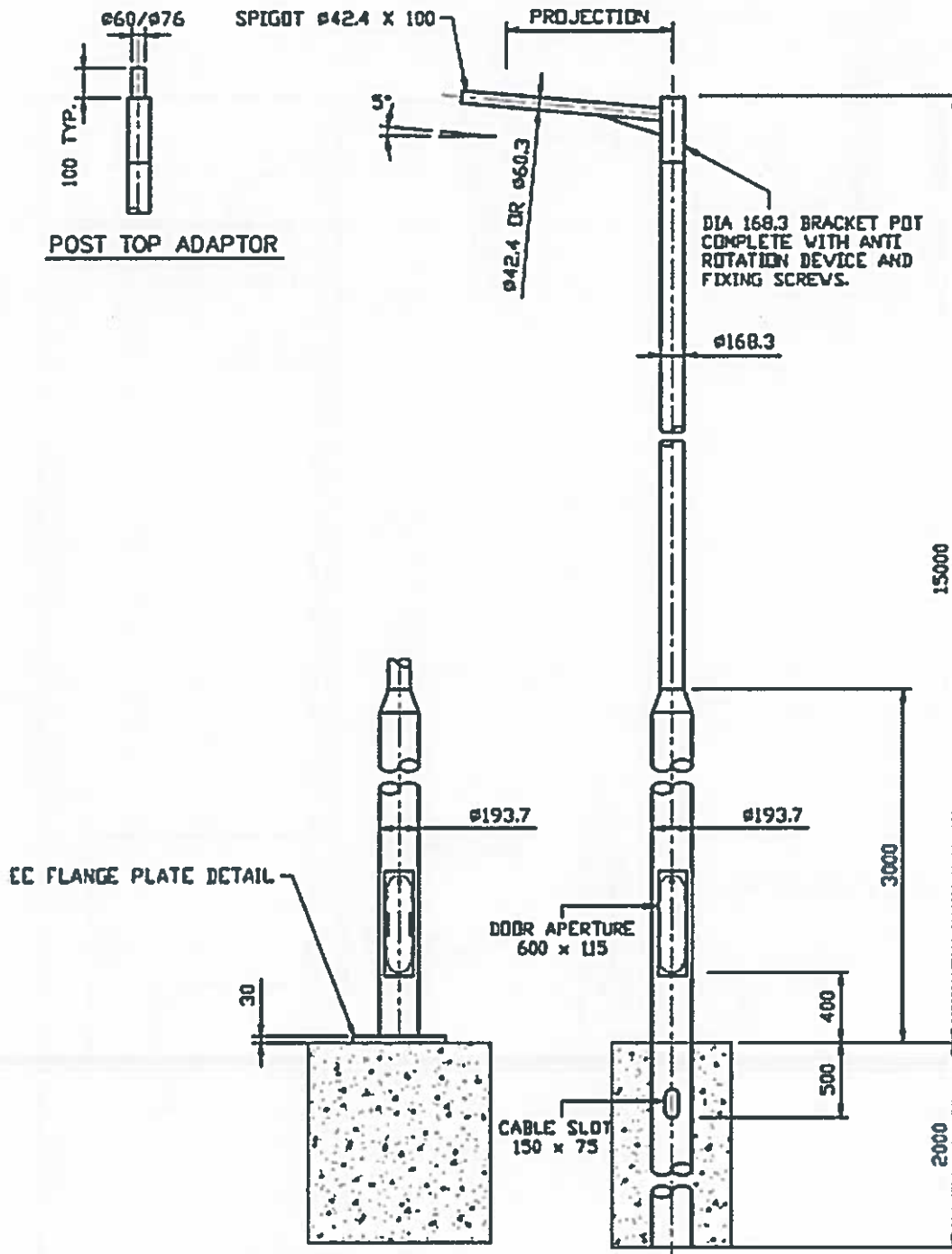

Fig. 1c. 15m Tubular Column Rooted and Flange Plated complete with various bracket arrangements

Issued by: Head of Section, Standards Development

Authorized by: Head of Department, Standards

Signed:



Signed:



Date: 2015-10-08

Date: 2015-10-08

TITLE:
SPECIFICATION FOR STREET LIGHTING ACCESSORIES

Doc. No.	KP1/6C.1/13/TSP/15/002
Issue No.	2
Revision No.	3
Date of Issue	2015-10-08
Page 68 of 79	

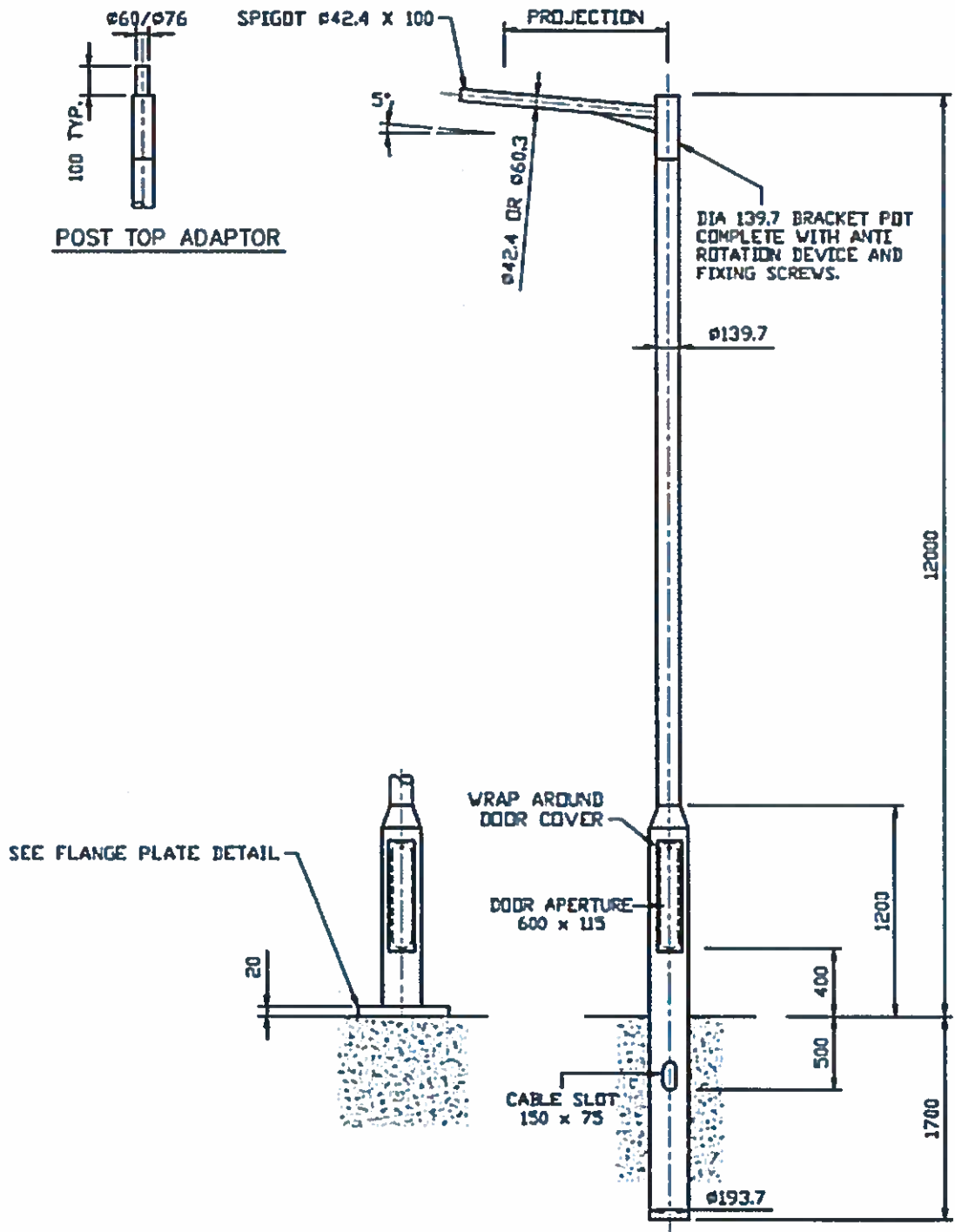

Fig. 2a. 12m Tubular Column Rooted and Flange Plated complete with various bracket arrangements

Issued by: Head of Section, Standards Development	Authorized by: Head of Department, Standards
Signed: 	Signed: 
Date: 2015-10-08	Date: 2015-10-08

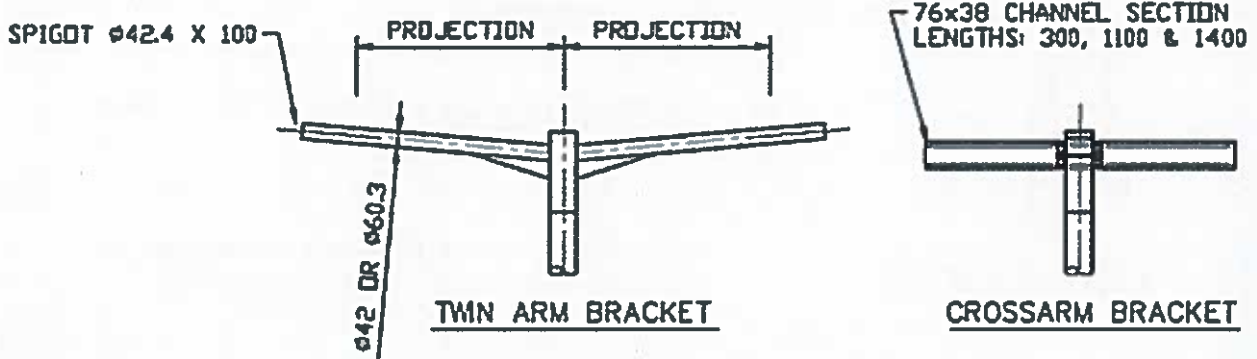

Fig. 2b. Twin and Crossarm Bracket Details for 12m column

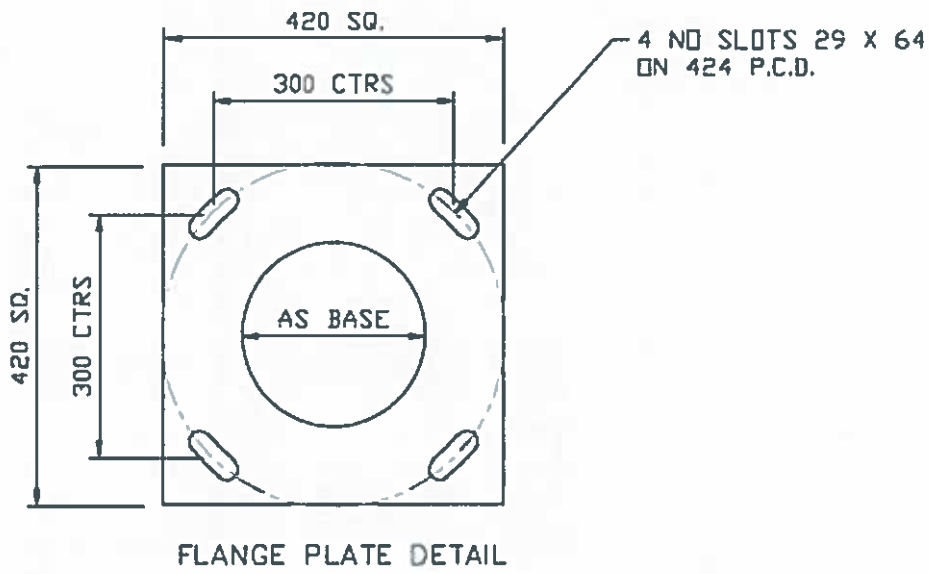

Fig. 2c. Flange Plate Detail for 12m column

Issued by: Head of Section, Standards Development

Authorized by: Head of Department, Standards

Signed:



Signed:



Date: 2015-10-08

Date: 2015-10-08

TITLE:
SPECIFICATION FOR STREET LIGHTING ACCESSORIES

Doc. No.	KP1/6C.1/13/TSP/15/002
Issue No.	2
Revision No.	3
Date of Issue	2015-10-08
Page 70 of 79	

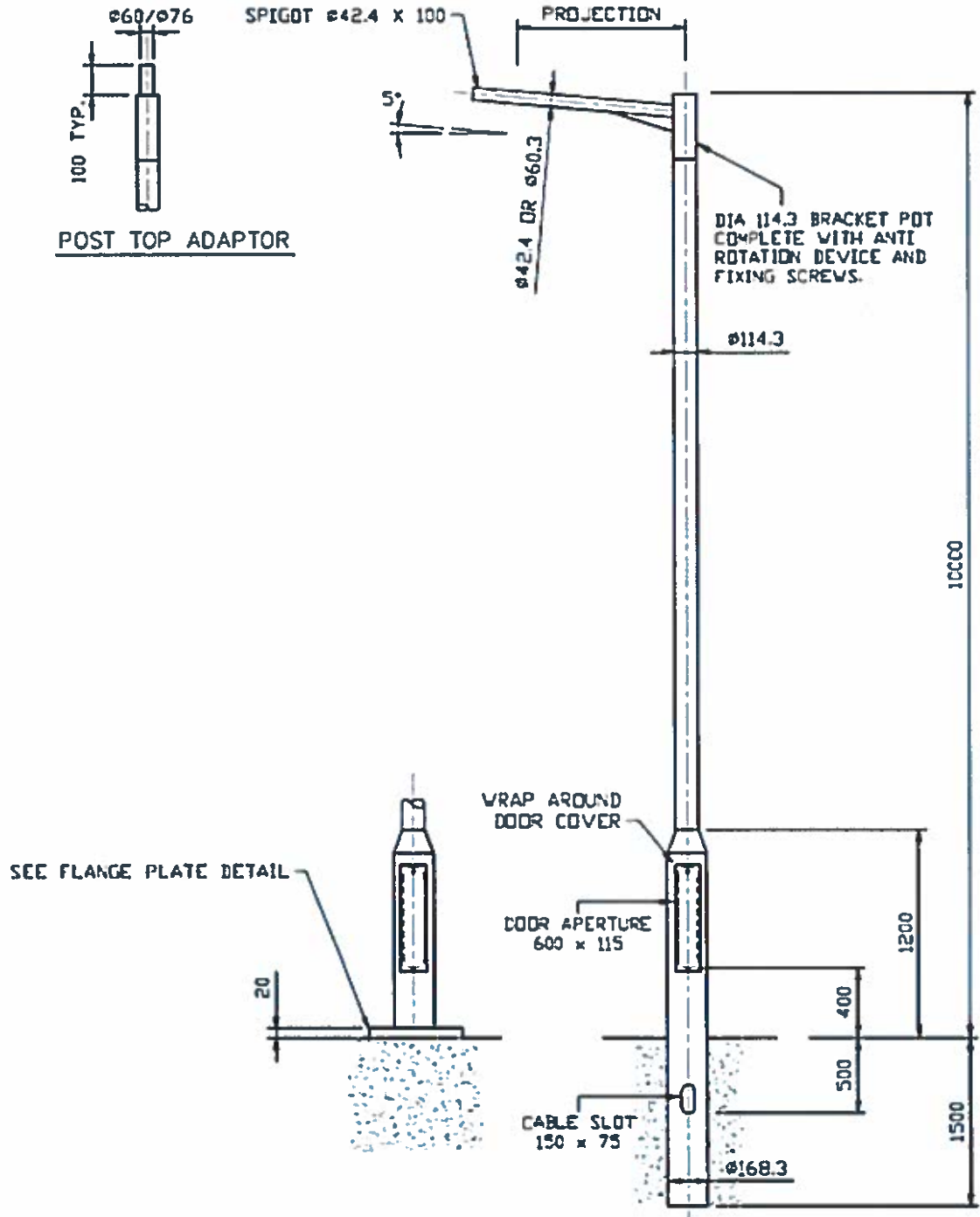



Fig. 3a. 10m Tubular Column Rooted and Flange Plated complete with various bracket arrangements

Issued by: Head of Section, Standards Development	Authorized by: Head of Department, Standards
Signed: 	Signed: 
Date: 2015-10-08	Date: 2015-10-08

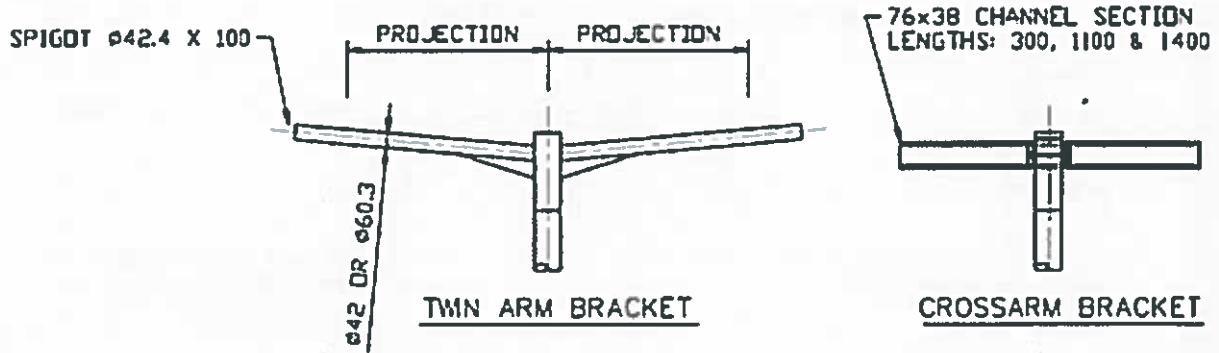

Fig. 3b. Twin and Crossarm Bracket Details for 10m column

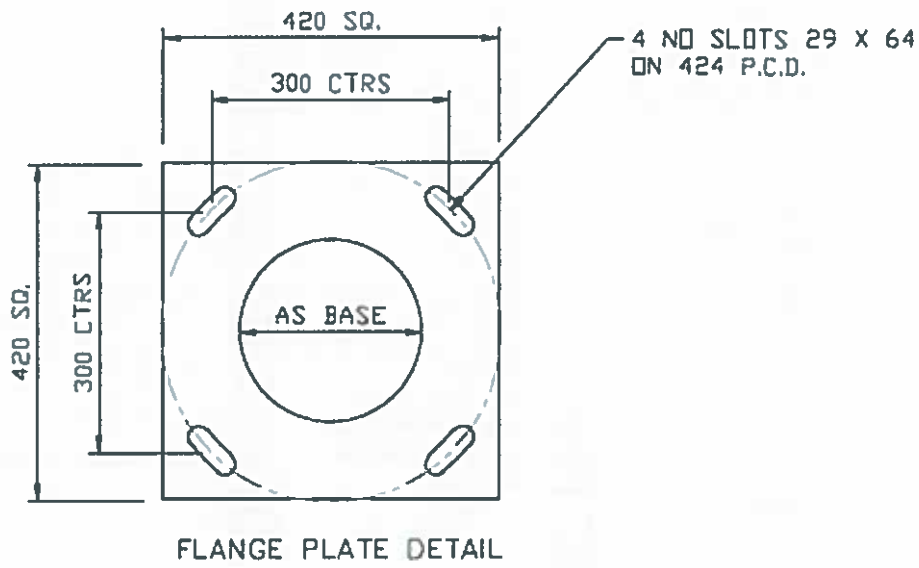

Fig. 3c. Flange Plate Detail for 10m column

Issued by: Head of Section, Standards Development

Authorized by: Head of Department, Standards

Signed:



Signed:



Date: 2015-10-08

Date: 2015-10-08

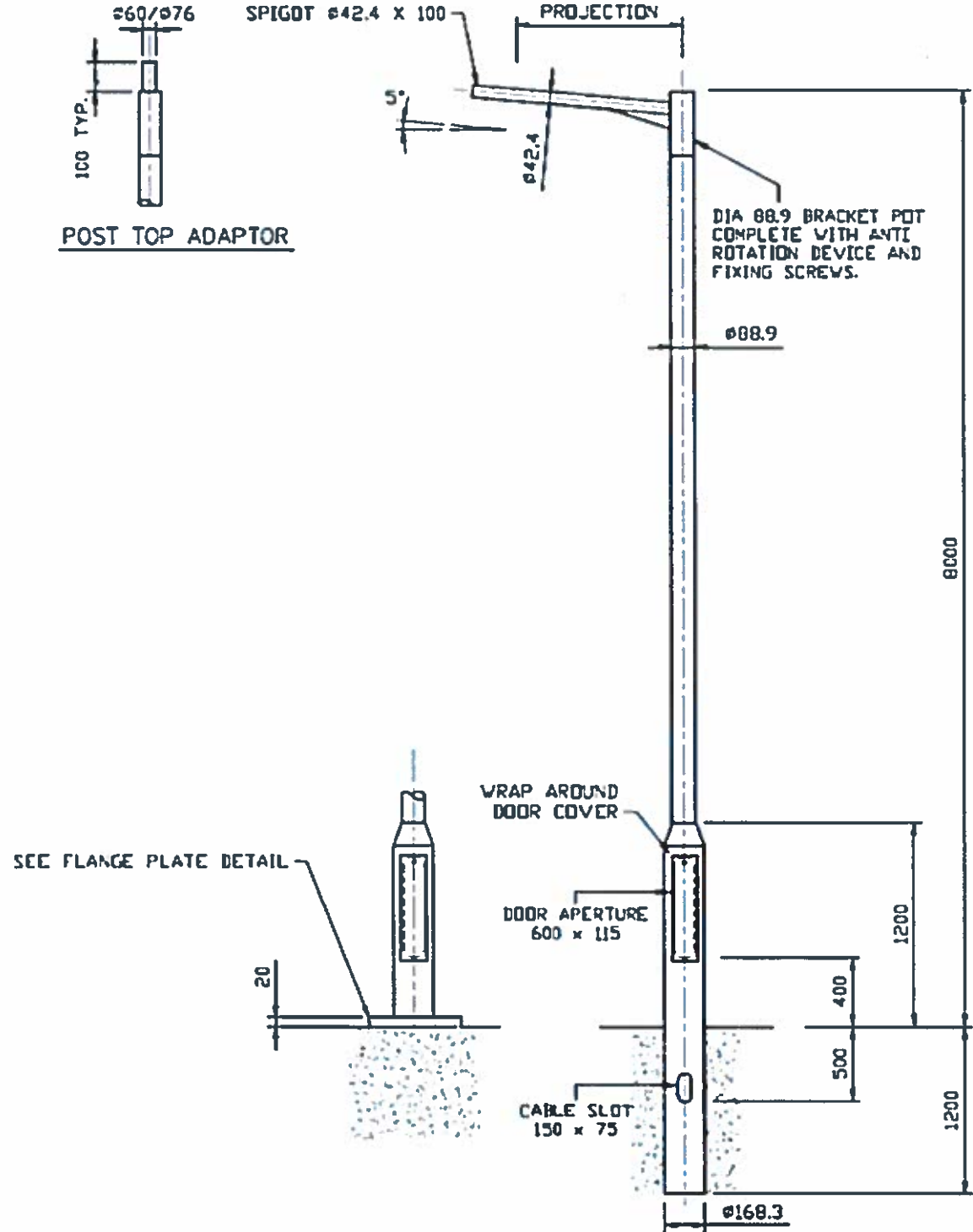



Fig. 4a. 8m Tubular Column Rooted and Flange Plated complete with various bracket arrangements

Issued by: Head of Section, Standards Development	Authorized by: Head of Department, Standards
Signed: 	Signed: 
Date: 2015-10-08	Date: 2015-10-08

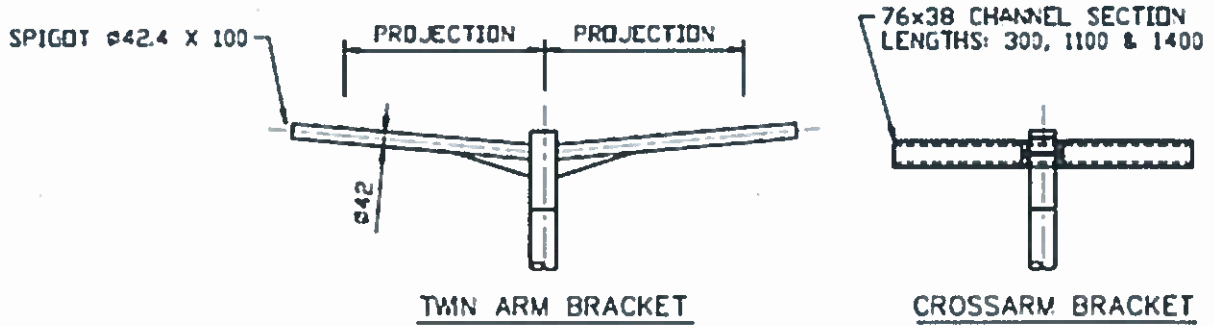

Fig. 4b. Twin and Crossarm Bracket Details for 8m column

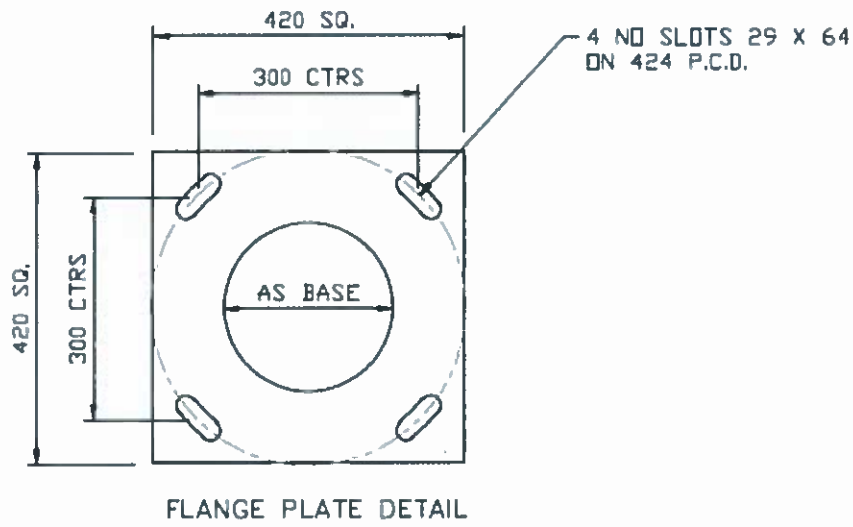

Fig. 4c. Flange Plate Detail for 8m column

Issued by: Head of Section, Standards Development

Authorized by: Head of Department, Standards

Signed:



Signed:



Date: 2015-10-08

Date: 2015-10-08

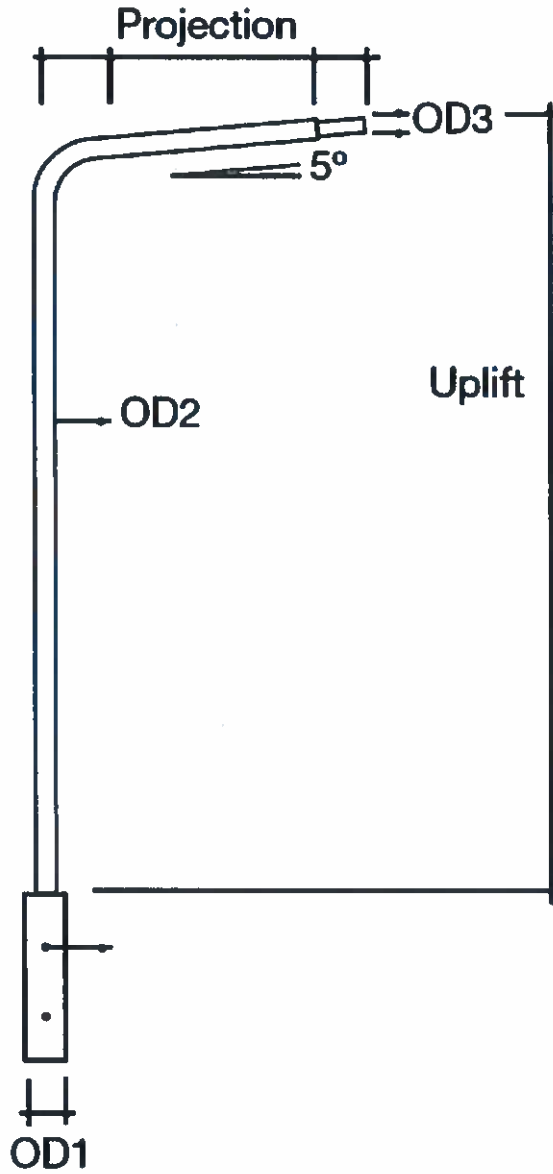

Fig. 5a: Uplift projection outreach bracket

Issued by: Head of Section, Standards Development

Authorized by: Head of Department, Standards

Signed:



Signed:



Date: 2015-10-08

Date: 2015-10-08

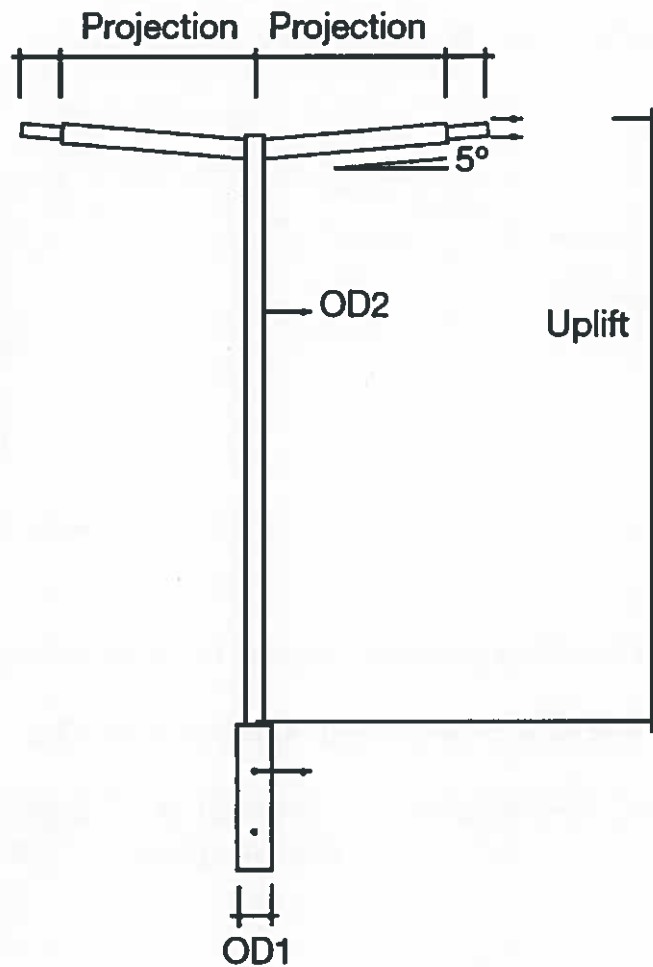

Fig. 5b: Uplift projection outreach bracket for 8m columns

Table 18: Dimensions of Fig. 5a & 5b

Projection mm	To fit uplift mm	To fit shaft or spigot mm	OD1 mm	OD2 mm	Approximate Weight	
					Single projection, Kg	Double projection, Kg
1,000	2,000	76	89	48	15	19.6
1,500	2,000	76	89	48	17.5	23.5
2,000	2,000	76	89	48	20	29.5

Issued by: Head of Section, Standards Development

Authorized by: Head of Department, Standards

Signed:



Signed:



Date: 2015-10-08

Date: 2015-10-08

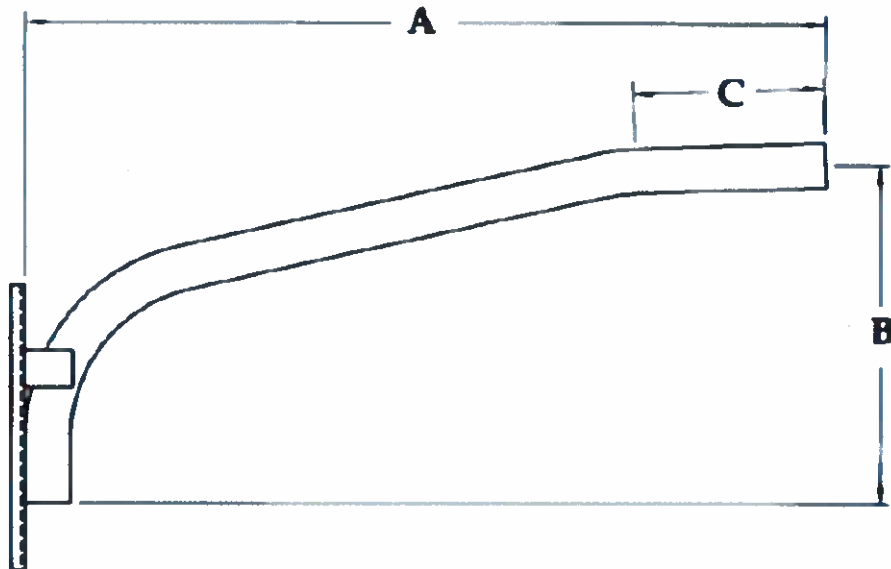



Fig. 6: Illustration of the of the streetlight column for wood or concrete pole mounting

19. Dimensions of the street light column in Fig. with BS EN 40-1 & 2

Outreach length A m	Dimensions B mm	Dimensions C mm	Diameter of shaft or spigot C mm	Diameter of the rest of the length mm	Thickness of tube mm
±10	±5	±5	±1	±1	+1
1,500	580	100	42	42 or 48	4
2,000	625	100	42	42 or 48	4
2,500	665	100	42	42 or 48	4
3,000	715	100	42	42 or 48	4

NOTE:

- Wood-pole mounting:** The column design shall be suitable for wood poles mounting using M16 x 9mm bolts and nuts and shall have two holes of 150mm apart positioned to offer.
- Concrete pole mounting:** The column design shall be suitable for concrete pole mounting using universal clamps using M20 with inter-hole spacing of 150mm.

Issued by: Head of Section, Standards Development	Authorized by: Head of Department, Standards
Signed: 	Signed: 
Date: 2015-10-08	Date: 2015-10-08

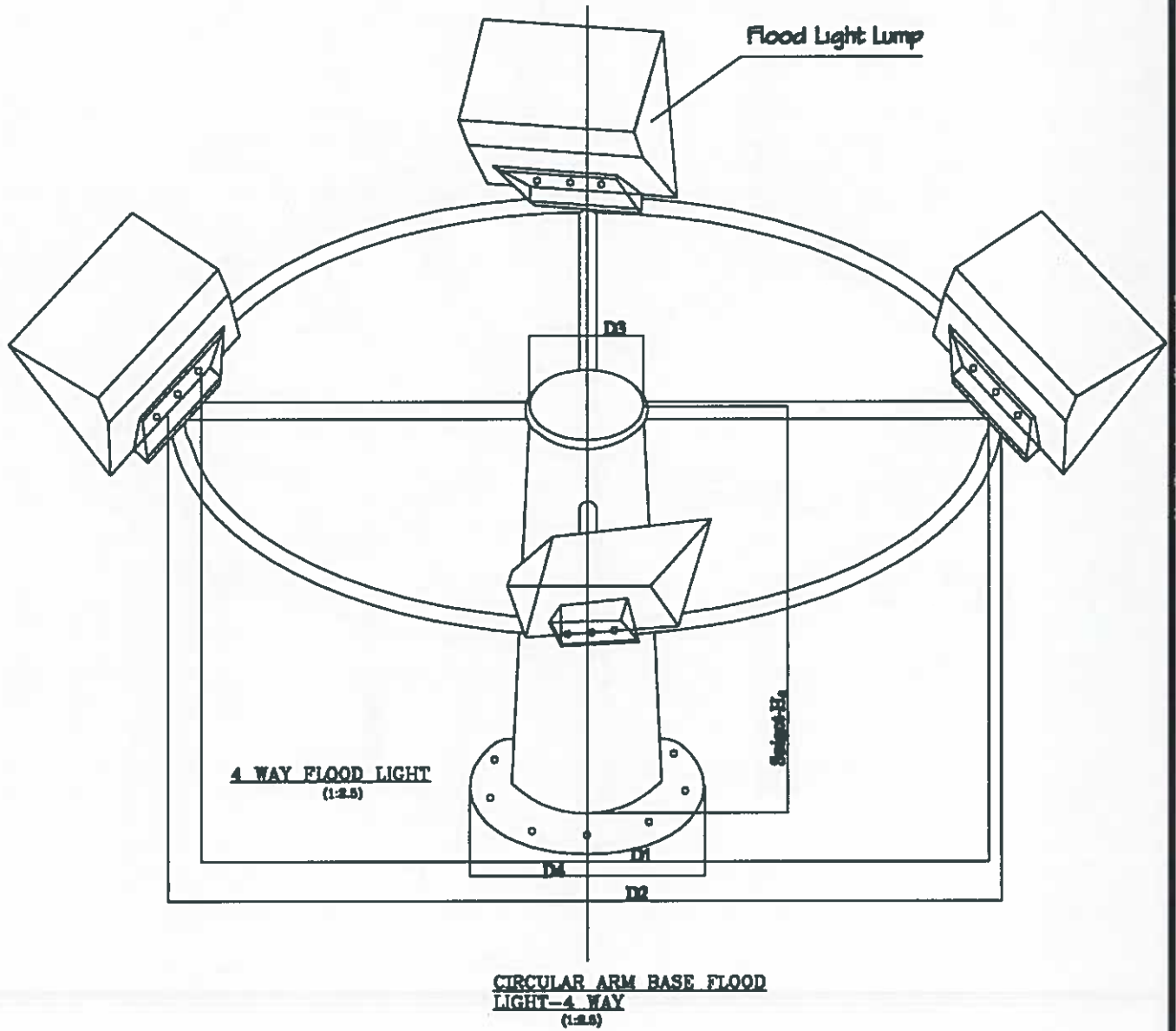

Fig. 7a: Illustration of a 4-way circular bracket for mounting floodlights

Issued by: Head of Section, Standards Development

Authorized by: Head of Department, Standards

Signed:



Signed:



Date: 2015-10-08

Date: 2015-10-08

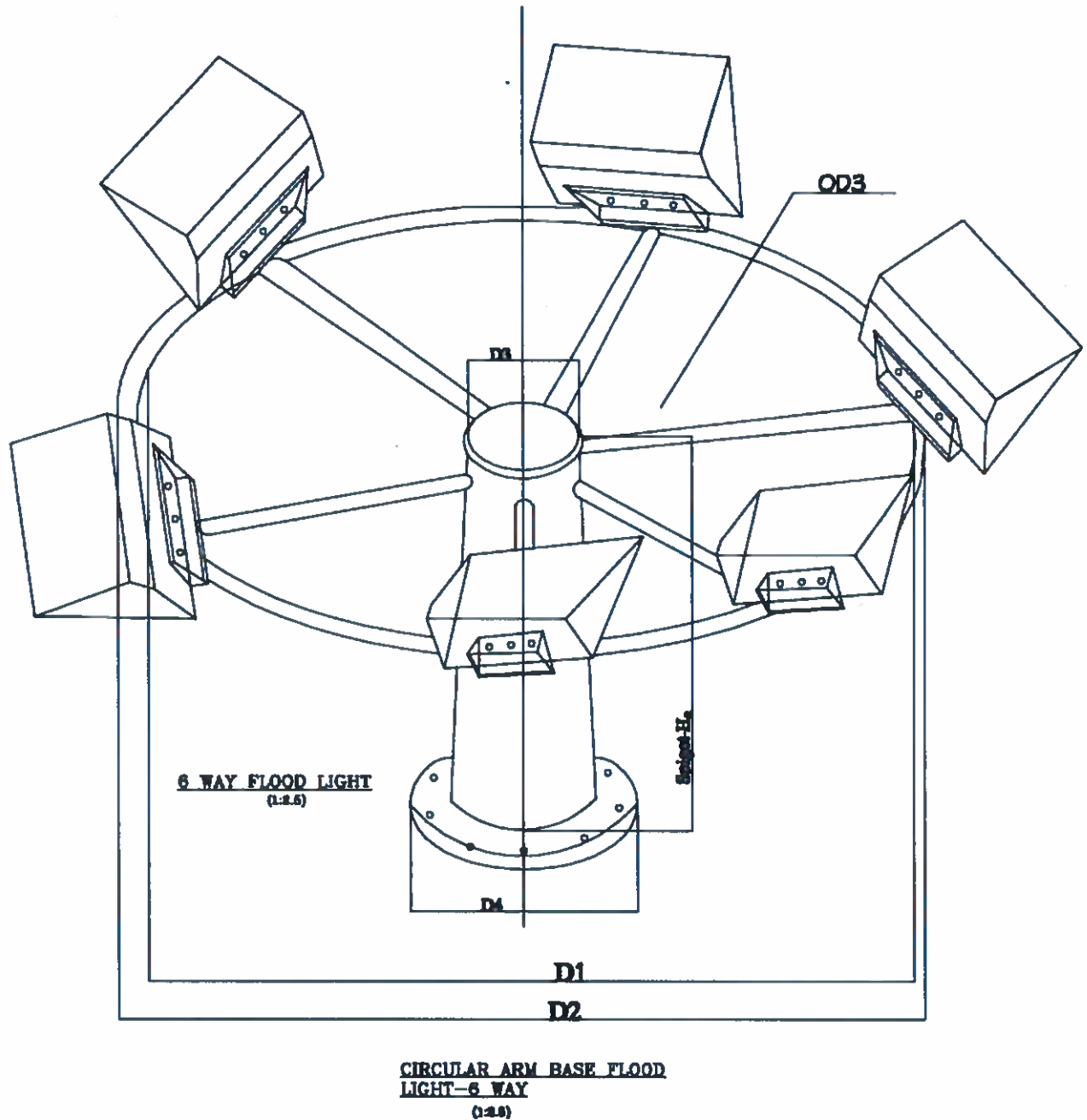

Fig. 8b: Illustration of a 6-way circular bracket for mounting floodlights

Issued by: Head of Section, Standards Development	Authorized by: Head of Department, Standards
Signed: 	Signed: 
Date: 2015-10-08	Date: 2015-10-08



TITLE:
SPECIFICATION FOR STREET LIGHTING ACCESSORIES

Doc. No.	KP1/6C.1/13/TSP/15/002
Issue No.	2
Revision No.	3
Date of Issue	2015-10-08
Page 79 of 79	

1.0. Dimensions of the circular brackets

Column Length m	Diameter, D1 m	Diameter, D2 m	D3 mm	D4 mm	Spigot height H₁	Tube Thickness mm
8	0.9-1.15	1.15-2.0	86	96	150	5
10	0.9-1.15	1.15-2.0	114.3	124.3	150	5
12	0.9-1.15	1.15-2.0	139.7	149.3	150	5
15	0.9-1.15	1.15-2.0	168.3	178.3	150	5

Issued by: Head of Section, Standards Development

Authorized by: Head of Department, Standards

Signed:

Signed:

Date: 2015-10-08

Date: 2015-10-08

